

# DC/AC TRMS mA CLAMP METER

## Model 11

### USERS MANUAL

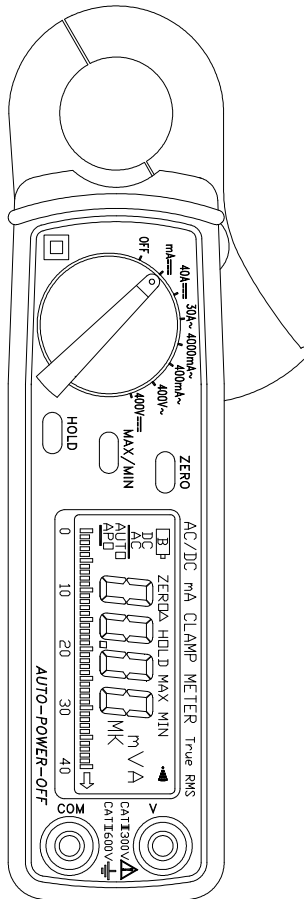



**PROVA INSTRUMENTS INC.**



**EN 61010-2-032**  
**CAT II 600V**  
**CAT III 300V**  
**Pollution Degree 2**

**SYMBOLS showed on the clamp meter or in this manual:**

	Caution, risk of danger. Refer to accompanying documents
	Caution, risk of electric shock.
	Double Insulation

**Overvoltage Category I (CAT I):**

Equipment for connection to circuits in which measures are taken to limit the transient overvoltages to an appropriate low level.

**Overvoltage Category II (CAT II):**

Energy-consuming equipment to be supplied from the fixed installation.

**Overvoltage Category III (CAT III):**

Equipment in fixed installations.

**WARNING:** If the clamp meter is used in a manner not specified by the manufacturer, the protection provided by the clamp meter may be impaired.

# TABLE OF CONTENTS

<b>1. Features</b>	1
<b>2. Panel Description</b>	2
<b>3. Operation Instructions</b>	4
<u>3.1. DC/AC Current Measurements</u>	4
<u>3.2. DC/AC Voltage Measurements</u>	5
<u>3.3. Relative Reading Measurements</u>	5
<u>3.4. Holding the LCD Reading</u>	6
<u>3.5. Finding the MAX/MIN Value</u>	6
<u>3.6. To Recover from Auto-Power-Off</u>	6
<b>4. Specifications</b>	7
<b>5. Battery Replacement</b>	9
<b>6. Maintenance &amp; Cleaning</b>	9

## **1. Features**

1. Accurate DC/AC digital clamp meter for current measurement.
2. 1mA DC / 0.1mA AC high resolution.
3. One touch zero for DCA adjustment.
4. 23 mm diameter jaw.
5. Large 3 3/4 digits LCD.
6. Fast bargraph display (30 times/sec.) for transient observation.
7. Max/Min and Data Hold functions.
8. Easy single rotary switch for any function selection.
9. Ideal for works in crowded switch box or cable areas.

## 2. Panel Description

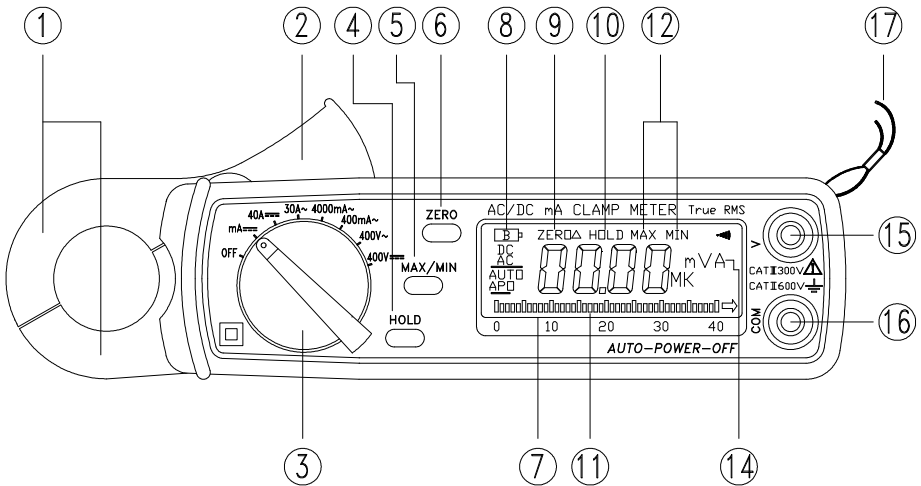

### 1. Transformer Jaw

This is used to pick up current signal. To measure DC/AC current, conductor must be enclosed by the jaw.

### 2. Transformer Trigger

This is used to open the jaw.

### 3. Function Selector and On/Off Switch

This is used to select the function user desired, such as DCA, ACA, DCV, ACV.

### 4. Data Hold Button

Once this button is pushed, reading shall be held on the LCD. Press again to release it.

### 5. Max/Min Hold Button

This button is used to enable the maximum or minimum value to be displayed and updated during measurement. Press once, minimum value shall be displayed and updated. Press again, maximum value shall be displayed and updated. Zero function will be disabled if MAX/MIN is enabled.

### 6. Zero/Relative Button

Once this button is pressed, the current reading shall be set to zero and be used as a zero reference value for all other subsequent measurement. The function is also used to remove offset value caused by the residual magnetism remained in the core

for the DC current measurement. The Zero/Relative function will be disabled if the MAX/MIN button is enabled.

#### 7. LCD

This is a 3 3/4 digit Liquid Crystal Display with maximum indication of 3999. Function symbols, units, bargraph, sign, decimal points, low battery symbols, max/min symbols, and zero symbol are included.

#### 8. Low Battery Symbol

When this symbol appears, it means the battery voltage drops below the minimum required voltage. Refer to Section V for battery replacement.

#### 9. Zero/Relative Symbol

When this symbol appears, it means a reference value has been subtracted from the actual reading. The reading shown is a offseted value. Press the zero button again to disable this function.

#### 10. Data Hold Symbol

Once the hold button is pressed, this symbol appears on LCD.

#### 11. Bargraph

Bargraph has forty segments. It displays segments proportional to the actual reading. Each segment represent one count.

#### 12. Max/Min Hold Symbol

Once the max/min button is pressed, either MAX or MIN shall be displayed on LCD.

#### 14. Units Symbols

Once a function is selected, corresponding unit (V, mA or A) shall be displayed on LCD.

#### 15. V Input Terminal

This terminal is used as input for voltage measurements.

#### 16. COM Terminal

This terminal is used as common reference input.

#### 17. Hand Strap

Put your hand through the hole of hand strap to avoid accidental drop of the clamp meter.

### 3. Operation Instructions

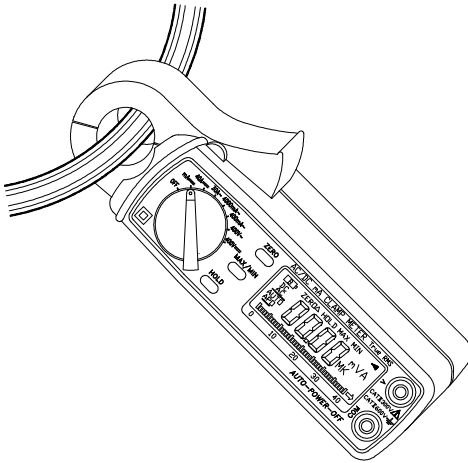

*Correct*

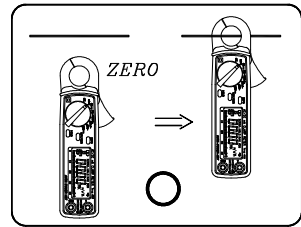

*Incorrect*

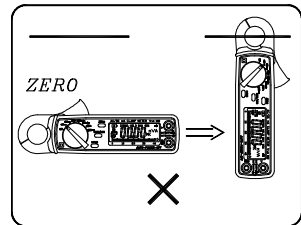

#### 3.1. DC/AC Current Measurements

**WARNING:** Make sure that all the test leads are disconnected from the meter's terminals for current measurement.

##### 3.1.1. DC Current

- Set the rotary switch at mA DC or 40A DC.
- Push the zero button to adjust the reading to zero. Due to the high sensitivity of the clamp meter, must zero in the same direction as in measurement to avoid interference by external magnetic field.
- Press the trigger to open the jaw and fully enclose the conductor to be measured. No air gap is allowed between the two half jaws.
- Read the measured value from the LCD display.

##### 3.1.2. AC Current

- Set the rotary switch at 400mA AC, 4000mA or 30A AC.
- Press the trigger to open the jaw and fully enclose the conductor to be measured. No air gap is allowed between the two half jaws.
- Read the measured value from the LCD display.

### 3.2. DC/AC Voltage Measurements

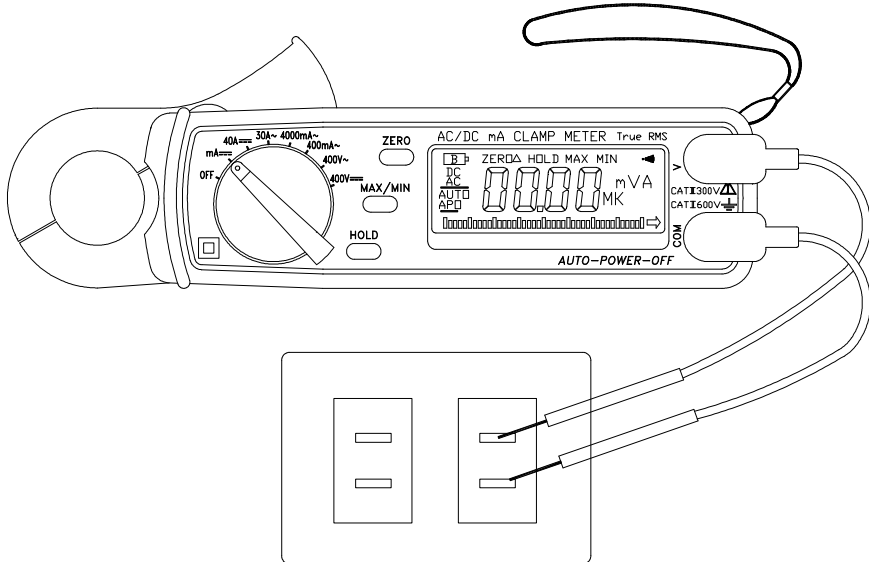

**WARNING:** Maximum input for DC V is 600, and for AC V is 600. Do not attempt to take any voltage measurement that exceeds the limits. Exceeding the limits could cause electrical shock and damage to the clamp meter.

#### 3.2.1. DC Voltage

- Set the rotary switch at V DC.
- Insert the test leads into the input jack.
- Connect the test prods of the test leads in PARALLEL to the circuit to be measured.
- Read the measured value from the LCD display.

#### 3.2.2. AC Voltage

- Set the rotary switch at V AC.
- Insert the test leads into the input jack.
- Connect the test prods of the test leads in PARALLEL to the circuit to be measured.
- Read the measured value from the LCD display.

### 3.3. Relative Reading Measurements

The zero button also can be used to make a relative measurement. Once the

button is pushed, the current reading is set to zero and a zero symbol shall be displayed on LCD. All the subsequent measurement shall be displayed as a relative value with respect to the value being zeroed. Press the zero button again to return to normal mode. But this function is disabled if MAX/MIN function is enabled. Please watch for symbol displayed on LCD.

<b>NOTE:</b> LCD displays relative numerical value without bargraph.
--

### 3.4. Holding the LCD Reading

Press the HOLD button, then the reading shall be hold and kept on LCD.

### 3.5. Finding the MAX/MIN Value

Press the MAX/MIN button to enable the maximum and minimum values to be recorded and updated during measurement. Push the button once, the maximum value shall be displayed and updated. The LCD display toggles between the MAX and MIN values. To exit MAX/MIN function, press and hold the MAX/MIN button for more than 2 seconds. The Zero/Relative function will be disabled if MAX/MIN function is enabled.

### 3.6. To Recover from Auto-Power-Off

The meter will turn itself off 15 minutes after power-on (A symbol of APO is displayed in LCD). Users can press HOLD button to turn the power on again. Or turn the rotary switch to OFF and wait for 3 sec., then turn the rotary switch to one of the measurement ranges to turn the power on again. Also pressing any button or turning the rotary switch will reset the 15 minute timer.

To disable the Auto-Power-Off function, hold the HOLD button while turning on power.

Press ZERO button for 2 sec. to enable or disable Auto-Power-Off function (APO).

#### 4. Specifications (23°C±5°C)

##### DC Current

Range	Resolution	Accuracy	Overload Protection
mA (0-4A)	1mA	±2.0%±3dgts	DC 40A
30A	10mA	±2.0%±3dgts	DC 100A
40A	10mA	±2.5%±3dgts	DC 100A

##### AC Current (True RMS, Crest Factor < 3)

Range	Resolution	Accuracy		Overload Protection
		50/60 Hz	40 - 100Hz	
400mA	0.1mA	±1.5%±5dgts	±2.0%±5dgts	AC 40A
4000mA	1mA	50/60 Hz	40 - 1KHz	AC 40A
		±2.5%±5dgts	±3.0%±5dgts	
30A	10mA	±2.0%±5dgts	±2.5%±5dgts	AC 100A

##### DC Voltage (Input Impedance: 10MΩ)

Range	Resolution	Accuracy	Overload Protection
400V	0.1V	±1.0%±2dgts	DC 1000V

##### AC Voltage (Input Impedance: 10MΩ, True RMS, Crest Factor < 3)

Range	Resolution	Accuracy		Overload Protection
		50/60 Hz	40 - 1KHz	
400V	0.1V	±1.5%±4dgts	±2.0%±5dgts	AC 800V

Indoor Use

Conductor Size:	23mm max. (approx.)
Battery Type:	two 1.5V SUM-3
Display:	3 3/4 LCD with 40 seg. bargraph
Range Selection:	manual
Overload Indication:	OL
Power Consumption:	15 mA (approx.)
Low battery Indication:	
Sampling Time:	3 times/sec. (display) 30 times/sec. (bargraph)
Operating Temperature:	-10°C to 50°C
Operating Humidity:	less than 85% relative
Altitude:	up to 2000M
Storage Temperature:	-20°C to 60°C
Storage Humidity:	less than 75% relative
Dimension:	183mm (L) x 61.3mm (W) x 35.6mm (H) 7.2" (L) x 2.5" (W) x 1.4" (H)
Weight:	190g (battery included)
Accessories:	Carrying bag x 1 Users manual x 1 1.5V battery x 2 Test leads x 1

## 5. Battery Replacement

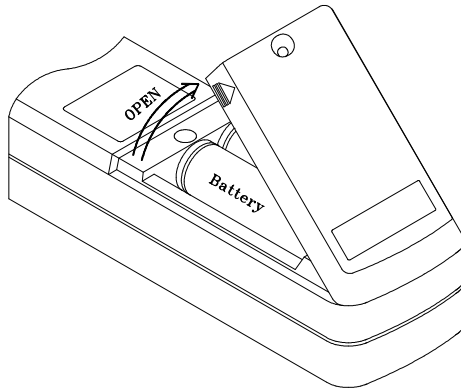

When the low battery symbol is displayed on the LCD, replace the old batteries with two new batteries.

- 5.1. Turn the power off and remove the test leads from the clamp meter.
- 5.2. Remove the screw of the battery compartment.
- 5.3. Lift and remove the battery compartment.
- 5.4. Remove the old batteries.
- 5.5. Insert two new 1.5V SUM-3 batteries.
- 5.6. Replace the battery compartment and secure the screw.

## 6. Maintenance & Cleaning

Servicing not covered in this manual should only be performed by qualified personnel. Repairs should only be performed by qualified personnel.

Periodically wipe the case with a damp cloth and detergent; do not use abrasives or solvents.

Address of Agent, Distributor, Importer, or Manufacturer

--