

Universal Process Calibrator
MCS-XV



MCS-XV-RM



MCS-XV-DT

TECHNICAL MANUAL

IMPORTANT INSTRUCTIONS:

- Keep the calibrator in a dry environment whenever possible.
- The fuse which protects the current measurement circuit, code 01.02.0277-21, is a special part. So, only replace the fuse by another original from factory.
- In case of failure, always send the instrument to the factory for repair.
- When not in daily use, before starting up, let the calibrator be turned on for at least one hour.

This technical manual refers to software version number **4.5.2**. (Press the icon  on the main menu to know the software version of your calibrator).

To stay informed about updates or ask questions, please send an e-mail to the address advancedcalibrators@presys.com.br or register your product in www.presyscorp.com

Table of contents

1 - Introduction.....	1
1.1. General Description.....	1
1.2. Specifications – Inputs	2
1.3. Specifications – Outputs.....	5
1.4. Optional Items	8
1.5. General Specifications	9
1.6. Special Software Features	12
1.7. Order Code	13
2 - Operation.....	14
2.1. Parts Identification.....	14
2.2. Battery and Charger (only for MCS-XV Portable Version)	19
2.3. Using MCS-XV: Basic Functions	21
2.4. Calibrator.....	22
2.4.1. Measurement or Input Functions	24
2.4.2. Generation or Output Functions	33
2.4.3. Available Power Supplies	37
2.4.4. Input Special Functions	38
2.4.5. Output Special Functions.....	42
2.4.6. Saving Current Configuration (Memory Manager)	46
2.4.7. Calibration Examples.....	46
2.5. HART®.....	51
2.5.1. HART® Connections.....	52
2.5.2. Starting Communication	55

2.5.3. Adjusting the Measurement Range of a HART® Transmitter (CH Option)	56
2.5.4. Adjusting the Measurement Range of a HART® Transmitter with Reference (CH Option).....	57
2.5.5. Checking / Adjusting HART® Transmitter mA Output (CH Option).....	60
2.5.6. Full-Hart Configurator (FH Option).....	61
2.6. Data Logger	66
2.7. Automatic Tasks.....	68
2.7.1. Creating Tasks.....	68
2.7.2. Performing Tasks.....	71
2.7.3. Viewing Results	73
2.8. Videos	76
3 - Settings.....	76
3.1. Date and Time.....	76
3.2. Network	77
3.3. System	77
4 - Adjustment.....	79
4.1. Input adjustment (IN).....	80
4.2. Output adjustment (OUT)	82
4.3. Pressure Calibration.....	85
5 - Maintenance	86
5.1. Replacing Battery (only for MCS-XV Portable)	86
5.2. Replacing Current Input Fuse	88
6 - Pressure Units Conversion.....	90
Notes	91

1 - Introduction

1.1. General Description

MCS-XV Process Calibrator enables measurement and generation of signals used in instrumentation and process control. Provides all features required for easier calibration and adjustment services on process instruments. It has high levels of accuracy, including aspects relating to changes in room temperature and maintains the specifications over long periods of time.

Designed for field use, includes useful items as: carrying case, holders with fastener rings or belts for a hands-free operation, 5.7" display with LED backlight for a better viewing in poor lighting conditions, rechargeable battery and large memory capacity to store the values obtained during calibrations enabling the transfer of these to the PC when needed. In addition, several constructive features that add quality and efficiency to MCS-XV, allowing its on-field and workbench use (**RM** Version – 19" Rack Mounting, **DT** Version – Desktop).

Incorporates state-of-the-art concepts of automatic calibration and adjustment via computer. Instrument and computer share measurement data obtained for a more efficient handling of information such as report and certificate issues, automatic work management, data sorting and storage, for an overall coverage of quality procedure requirements, especially those related to ISO-9000.

It has HART® communication for reading and setting parameters of field devices that have this protocol.

Can be supplied with up to four pressure sensors. Thus, a single calibrator can have different ranges of pressure, for example vacuum, 0 to 100 psi, 0 to 1,000 psi and 0 to 3,000 psi, or any combination of available ranges. Can also be purchased with a certain number of sensors, which may be later increased.

Another optional item is a high accuracy sensor, which among its many functions can work as a standard thermometer. Thus, while indicating the reference temperature, allows the calibration of another temperature sensor.

1.2. Specifications – Inputs

Input Ranges	Resolution	Accuracy	Remarks
millivolt -150 mV to 150 mV -500 mV to -150 mV 150 mV to 2450 mV	0.001 mV 0.01 mV 0.01 mV	$\pm 0.01\% \text{ FS}^*$ $\pm 0.02\% \text{ FS}$ $\pm 0.02\% \text{ FS}$	$R_{\text{input}} > 10 \text{ M}\Omega$ auto-ranging
volt -10 V to 11 V 11 V to 45 V	0.0001 V 0.0001 V	$\pm 0.02\% \text{ FS}$ $\pm 0.02\% \text{ FS}$	$R_{\text{input}} > 1 \text{ M}\Omega$
mA -5 mA to 24.5 mA	0.0001 mA	$\pm 0.02\% \text{ FS}$	$R_{\text{input}} < 120 \Omega$
resistance 0 to 400 Ω 400 to 2500 Ω	0.01 Ω 0.01 Ω	$\pm 0.01\% \text{ FS}$ $\pm 0.03\% \text{ FS}$	Excitation current 0.85 mA, auto-ranging
frequency ** 0 to 600 Hz 600 to 1300 Hz 1300 to 5000 Hz	0.01 Hz 0.1 Hz 1 Hz	$\pm 0.04 \text{ Hz}$ $\pm 0.2 \text{ Hz}$ $\pm 2 \text{ Hz}$	$R_{\text{input}} > 50 \text{ k}\Omega$ Voltage $\text{DC}_{\text{max}} = 30 \text{ V}$ AC Signal from 0.3 to 30 V auto-ranging
counter ** 0 to $10^8 - 1$ count	1 count	-----	Same as frequency. Pulse frequency < 3000 Hz

(*) FS = Full Scale.

(**) Function available since the frequency output is not configured.

Input Ranges	Resolution	Accuracy	Remarks
Pt-100 -200 to 850 °C / -328 to 1562 °F	0.01 °C / 0.01 °F	± 0.1 °C / ± 0.2 °F	IEC 60751
Pt-1000 -200 to 400 °C / -328 to 752 °F	0.1 °C / 0.1 °F	± 0.1 °C / ± 0.2 °F	IEC 60751
Cu-10 -200 to 260 °C / -328 to 500 °F	0.1 °C / 0.1 °F	± 2.0 °C / ± 4.0 °F	Minco 16-9
Ni-100 -60 to 250 °C / -76 to 482 °F	0.1 °C / 0.1 °F	± 0.2 °C / ± 0.4 °F	DIN-43760
Probe* -200 to 850 °C / -328 to 1562 °F	0.01 °C / 0.01 °F	± 0.1 °C / ± 0.2 °F	IEC 60751
TC-J -210 to 1200 °C / -346 to 2192 °F	0.1 °C / 0.1 °F	± 0.2 °C / ± 0.4 °F	IEC 60584
TC-K -270 to -150 °C / -454 to -238 °F	0.1 °C / 0.1 °F	± 0.5 °C / ± 1.0 °F	IEC 60584
TC-K -150 to 1370 °C / -238 to 2498 °F	0.1 °C / 0.1 °F	± 0.2 °C / ± 0.4 °F	IEC 60584
TC-T -260 to -200 °C / -436 to -328 °F	0.1 °C / 0.1 °F	± 0.6 °C / ± 1.2 °F	IEC 60584
TC-T -200 to -75 °C / -328 to -103 °F	0.1 °C / 0.1 °F	± 0.4 °C / ± 0.8 °F	IEC 60584
TC-T -75 to 400 °C / -103 to 752 °F	0.1 °C / 0.1 °F	± 0.2 °C / ± 0.4 °F	IEC 60584
TC-B 50 to 250 °C / 122 to 482 °F	0.1 °C / 0.1 °F	± 2.5 °C / ± 5.0 °F	IEC 60584
TC-B 250 to 500 °C / 482 to 932 °F	0.1 °C / 0.1 °F	± 1.5 °C / ± 3.0 °F	IEC 60584
TC-B 500 to 1200 °C / 932 to 2192 °F	0.1 °C / 0.1 °F	± 1.0 °C / ± 2.0 °F	IEC 60584
TC-B 1200 to 1820 °C / 2192 to 3308 °F	0.1 °C / 0.1 °F	± 0.7 °C / ± 1.4 °F	IEC 60584

(*) **Probe** is an input for a reference RTD in order to use as standard thermometer. The accuracy is related only to MCS-XV.

Input Ranges	Resolution	Accuracy	Remarks
TC-R -50 to 300 °C / -58 to 572 °F	0.1 °C / 0.1 °F	± 1.0 °C / ± 2.0 °F	IEC 60584
TC-R 300 to 1760 °C / 572 to 3200 °F	0.1 °C / 0.1 °F	± 0.7 °C / ± 1.4 °F	IEC 60584
TC-S -50 to 300 °C / -58 to 572 °F	0.1 °C / 0.1 °F	± 1.0 °C / ± 2.0 °F	IEC 60584
TC-S 300 to 1760 °C / 572 to 3200 °F	0.1 °C / 0.1 °F	± 0.7 °C / ± 1.4 °F	IEC 60584
TC-E -270 to -150 °C / -454 to -238 °F	0.1 °C / 0.1 °F	± 0.3 °C / ± 0.6 °F	IEC 60584
TC-E -150 to 1000 °C / -238 to 1832 °F	0.1 °C / 0.1 °F	± 0.1 °C / ± 0.2 °F	IEC 60584
TC-N -260 to -200 °C / -436 to -328 °F	0.1 °C / 0.1 °F	± 1.0 °C / ± 2.0 °F	IEC 60584
TC-N -200 to -20 °C / -328 to -4 °F	0.1 °C / 0.1 °F	± 0.4 °C / ± 0.8 °F	IEC 60584
TC-N -20 to 1300 °C / -4 to 2372 °F	0.1 °C / 0.1 °F	± 0.2 °C / ± 0.4 °F	IEC 60584
TC-L -200 to 900 °C / -328 to 1652 °F	0.1 °C / 0.1 °F	± 0.2 °C / ± 0.4 °F	DIN-43710
TC-C 0 to 1500 °C / 32 to 2732 °F	0.1 °C / 0.1 °F	± 0.5 °C / ± 1.0 °F	W5Re / W26Re
TC-C 1500 to 2320 °C / 2732 to 4208 °F	0.1 °C / 0.1 °F	± 0.7 °C / ± 1.4 °F	W5Re / W 26Re

1.3. Specifications – Outputs

	Output Ranges	Resolution	Accuracy	Remarks
	millivolt -10 mV to 110 mV	0.001 mV	± 0.02 % FS	$R_{out} < 0.3 \Omega$
	volt -0.5 V to 12 V	0.0001 V	± 0.02 % FS	$R_{out} < 0.3 \Omega$
	mA 0 to 24 mA	0.0001 mA	± 0.02 % FS	$R_{max} = 700 \Omega$
	(XTR) 2-wire Transmitter 4 mA to 24 mA	0.0001 mA	± 0.02 % FS	$V_{max} = 60 V$
	Resistance 0 to 400 Ω 400 to 2500 Ω	0.01 Ω 0.1 Ω	± 0.02 % FS ± 0.03 % FS	For external excitation current of 1.0 mA
	Frequency* 0 to 100 Hz 0 to 10000 Hz	0.01 Hz 1 Hz	± 0.02 Hz ± 2 Hz	Peak value: 22 V / 25 mA max.
	Pulse* 0 to 10^8 – 1 pulses	1 pulse	_____	Peak value: 22 V / 25 mA max. Pulses frequency up to 10000 Hz
	Pt-100 -200 to 850 $^{\circ}C$ / -328 to 1562 $^{\circ}F$	0.01 $^{\circ}C$ / 0.01 $^{\circ}F$	± 0.2 $^{\circ}C$ / ± 0.4 $^{\circ}F$	IEC 60751
	Pt-1000 -200 to 400 $^{\circ}C$ / -328 to 752 $^{\circ}F$	0.1 $^{\circ}C$ / 0.1 $^{\circ}F$	± 0.1 $^{\circ}C$ / ± 0.2 $^{\circ}F$	IEC 60751
	Cu-10 -200 to 260 $^{\circ}C$ / -328 to 500 $^{\circ}F$	0.1 $^{\circ}C$ / 0.1 $^{\circ}F$	± 2.0 $^{\circ}C$ / ± 4.0 $^{\circ}F$	Minco 16-9
	Ni-100 -60 to 250 $^{\circ}C$ / -76 to 482 $^{\circ}F$	0.1 $^{\circ}C$ / 0.1 $^{\circ}F$	± 0.2 $^{\circ}C$ / ± 0.4 $^{\circ}F$	DIN-43760

(*) Function available since the frequency input is not configured.

Output Ranges	Resolution	Accuracy	Remarks
TC-J -210 to 1200 °C / -346 to 2192 °F	0.1 °C / 0.1 °F	± 0.4 °C / ± 0.8 °F	IEC 60584
TC-K -270 to -150 °C / -454 to -238 °F	0.1 °C / 0.1 °F	± 1.0 °C / ± 2.0 °F	IEC 60584
TC-K -150 to 1370 °C / -238 to 2498 °F	0.1 °C / 0.1 °F	± 0.4 °C / ± 0.8 °F	IEC 60584
TC-T -260 to -200 °C / -436 to -328 °F	0.1 °C / 0.1 °F	± 1.2 °C / ± 2.4 °F	IEC 60584
TC-T -200 to -75 °C / -328 to -103 °F	0.1 °C / 0.1 °F	± 0.8 °C / ± 1.6 °F	IEC 60584
TC-T -75 to 400 °C / -103 to 752 °F	0.1 °C / 0.1 °F	± 0.4 °C / ± 0.8 °F	IEC 60584
TC-B 50 to 250 °C / 122 to 482 °F	0.1 °C / 0.1 °F	± 5.0 °C / ± 10.0 °F	IEC 60584
TC-B 250 to 500 °C / 482 to 932 °F	0.1 °C / 0.1 °F	± 3.0 °C / ± 6.0 °F	IEC 60584
TC-B 500 to 1200 °C / 932 to 2192 °F	0.1 °C / 0.1 °F	± 2.0 °C / ± 4.0 °F	IEC 60584
TC-B 1200 to 1820 °C / 2192 to 3308 °F	0.1 °C / 0.1 °F	± 1.4 °C / ± 2.8 °F	IEC 60584
TC-R -50 to 300 °C / -58 to 572 °F	0.1 °C / 0.1 °F	± 2.0 °C / ± 4.0 °F	IEC 60584
TC-R 300 to 1760 °C / 572 to 3200 °F	0.1 °C / 0.1 °F	± 1.4 °C / ± 2.8 °F	IEC 60584
TC-S -50 to 300 °C / -58 to 572 °F	0.1 °C / 0.1 °F	± 2.0 °C / ± 4.0 °F	IEC 60584
TC-S 300 to 1760 °C / 572 to 3200 °F	0.1 °C / 0.1 °F	± 1.4 °C / ± 2.8 °F	IEC 60584
TC-E -270 to -150 °C / -454 to -238 °F	0.1 °C / 0.1 °F	± 0.6 °C / ± 1.2 °F	IEC 60584
TC-E -150 to 1000 °C / -238 to 1832 °F	0.1 °C / 0.1 °F	± 0.2 °C / ± 0.4 °F	IEC 60584

Output Ranges	Resolution	Accuracy	Remarks
TC-N -260 to -200 °C / -436 to -328 °F	0.1 °C / 0.1 °F	± 2.0 °C / ± 4.0 °F	IEC 60584
TC-N -200 to -20 °C / -328 to -4 °F	0.1 °C / 0.1 °F	± 0.8 °C / ± 1.6 °F	IEC 60584
TC-N -20 to 1300 °C / -4 to 2372 °F	0.1 °C / 0.1 °F	± 0.4 °C / ± 0.8 °F	IEC 60584
TC-L -200 to 900 °C / -328 to 1652 °F	0.1 °C / 0.1 °F	± 0.4 °C / ± 0.8 °F	DIN-43710
TC-C 0 to 1500 °C / 32 to 2732 °F	0.1 °C / 0.1 °F	± 0.5 °C / ± 1.0 °F	W5Re / W26Re
TC-C 1500 to 2320 °C / 2732 to 4208 °F	0.1 °C / 0.1 °F	± 0.7 °C / ± 1.4 °F	W5Re / W 26Re

Accuracy values are valid within one year and temperature range of 20 to 26 °C. Outside these limits add 0.001 % FS / °C taking 23 °C as the reference temperature. For thermocouples, using the internal cold junction compensation add a cold junction compensation error of ± 0.2 °C or ± 0.4 °F max.

1.4. Optional Items

Probe

Independent input for RTD (**Probe**). Probe is a high accuracy 4-wire Pt100 available under previous consult.

Pressure Sensors

Can be placed up to 4 pressure sensors in MCS-XV, with ranges between 250 mmH₂O and 10,000 psi.

Ranges *	Resolution	Accuracy	Remarks
(0) 0 – 250 mmH ₂ O	0.001	± 0.05 % FS**	Gage pressure.
(1) 0 – 1 psi	0.0001	± 0.05 % FS	Used with air or inert gases.
(2) 0 – 5 psi	0.0001	± 0.025 % FS	
(3) 0 – 15 psi	0.0001	± 0.025 % FS	Gage or absolute pressure. Used with fluids (gases or liquids) compatible with INOX 316 L stainless steel.
(4) 0 – 30 psi	0.0001	± 0.025 % FS	
(5) 0 – 100 psi	0.001	± 0.025 % FS	
(6) 0 – 250 psi	0.001	± 0.025 % FS	
(7) 0 – 500 psi	0.01	± 0.025 % FS	
(8) 0 – 1,000 psi	0.01	± 0.025 % FS	
(9) 0 – 3,000 psi	0.01	± 0.025 % FS	
(10) 0 – 5,000 psi	0.1	± 0.025 % FS	
(11) 0 – 10,000 psi	0.1	± 0.05 % FS	
(12) Others upon request			

(*) Gage pressure, absolute pressure (from range 3 to 8), vacuum (only for range 3), compound (from range 3 to 8), and differential (from range 0 to 2).

(**) FS = Full Scale

Note: Optional **BR (Barometric Reference – 15 psia)**

Sensor for ambient pressure measurement. Can be used for simulated indication of absolute pressure on the other sensors.

Pressure accuracy values are valid within one year and temperature range of 20 to 26 °C. Outside these limits add 0.005 % FS / °C taking 23 °C as the reference temperature. These values are obtained through algorithms of temperature compensation on pressure measurements.

1.5. General Specifications

RTD input for 2, 3 and 4 wires. Table IEC 60751, JIS or *Callendar-Van Dusen* user-configurable.

Regulated transmitter power supply (TPS): 24 Vdc, with protection for short circuit (30 mA).

Contact input for calibration of switches (pressure switch, thermo switch etc.).

50 Vdc in/out insulation.

Five minutes warm-up time.

Operating temperature range: 0 to 50 °C.

Relative Humidity: 0 to 90 % RH.

Pneumatic Connection: 1/4" NPTF (1/8" NPTF only for the range 0 – 10,000 psi).

Overpressure: up to twice the sensor full scale pressure (for sensors up to 5,000 psi).

Engineering units - Temperature: °C, °F, K, °R; Pressure: psi, bar, mbar, MPa, kPa, Pa, atm, at, mmH₂O@4°C, cmH₂O@4°C, ftH₂O@4°C, inH₂O@4°C, inH₂O@60°F, torr, mmHg@0°C, cmHg@0°C, inHg@0°C, inHg@60°F, gf/cm², kgf/cm², kgf/m².

Built in Web Server, Ethernet communication. USB port for software/firmware upgrade.

HART[®] Communication Protocol (optional).

Calibration Certificate (optional).

One-year warranty, except for rechargeable battery.

Portable Version (MCS-XV). Designed for field use.



Rechargeable battery, up to 8 hours of operation with current output in 12 mA and display brightness set to 50 percent.

Includes technical manual, test leads, carrying case and battery charger.

Dimensions: 140 mm x 250 mm x 80 mm (HxWxD).

Weight: 1.5 kg approx.

Rack Mounting Version (MCS-XV-RM). Designed for mounting on 19" rack or workbench.



Powered from 100 to 240 Vac, 50 / 60 Hz.
Includes technical manual and test leads.
Dimensions: 132 mm x 483 mm x 105 mm (HxWxD).
Weight: 4.0 kg approx.

Desktop Version (MCS-XV-DT). Designed for use on workbench.



Powered from 100 to 240 Vac, 50 / 60 Hz.
Includes technical manual and test leads.
Dimensions: 132 mm x 308 mm x 275 mm (HxWxD).
Weight: 3.0 kg approx.

Notes:

- * MCS-XV and ISOPLAN® are Presys trademarks.
- * Changes can be introduced in the instrument, altering specifications in this manual.
- * HART® is a *FieldComm Group* trademark.

1.6. Special Software Features

- Special Functions:

- 1) **SCALE**: makes the scaling of both input and output.
- 2) **CONV**: converts any input to any output, galvanically isolated.
- 3) **RAMP**: increasing or decreasing ramps with configurable ramp time and level mark.
- 4) **STEP**: steps or setpoints with configurable time.

- **Memory Manager**: stores configuration types predefined by the user.

- **Automated Tasks**: creating of calibration work orders and automatic execution of calibration services, storage of data and reporting.

- **Data Logger**: monitoring of input or output signals, storage and visualization of data in chart or table.

- **Videos**: storage and viewing videos on the calibrator screen.

1.7. Order Code

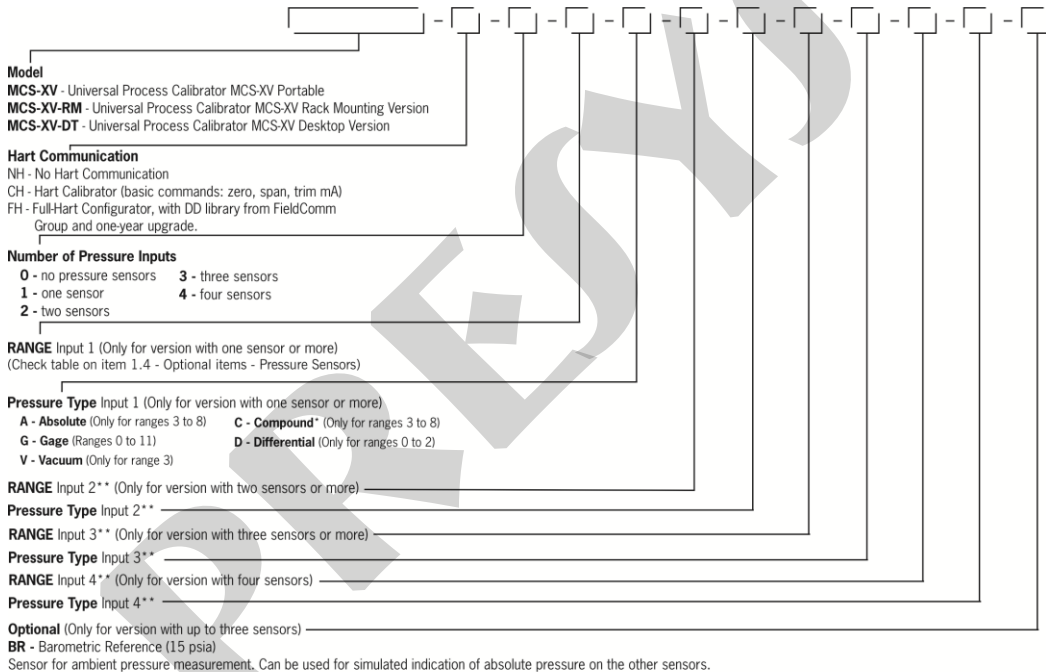

(*) From -15 psi to the full scale of range

(**) Same code as input 1

2 - Operation

2.1. Parts Identification

MCS-XV Portable Front Panel

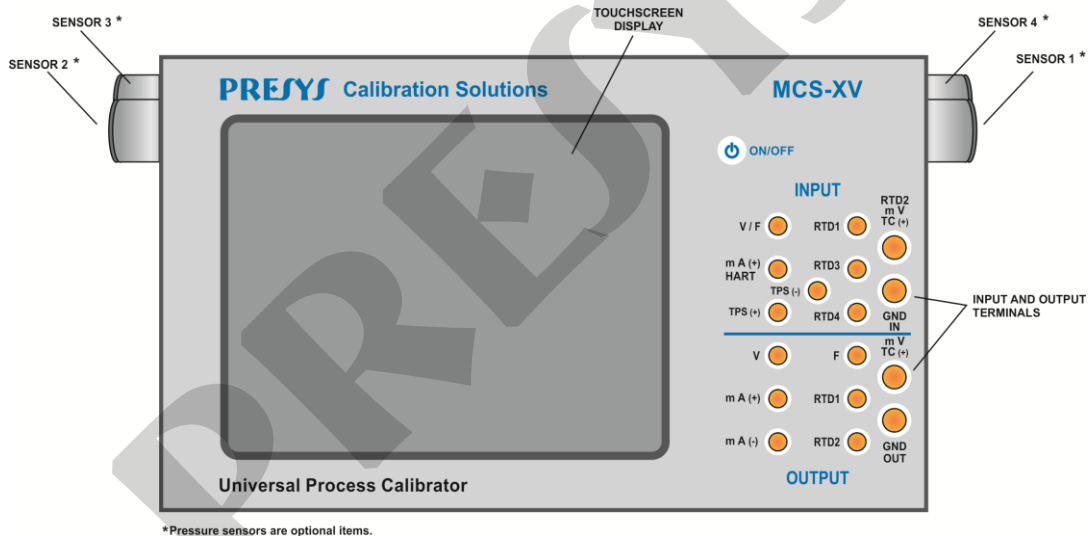

Fig. 01 - Front Panel – MCS-XV

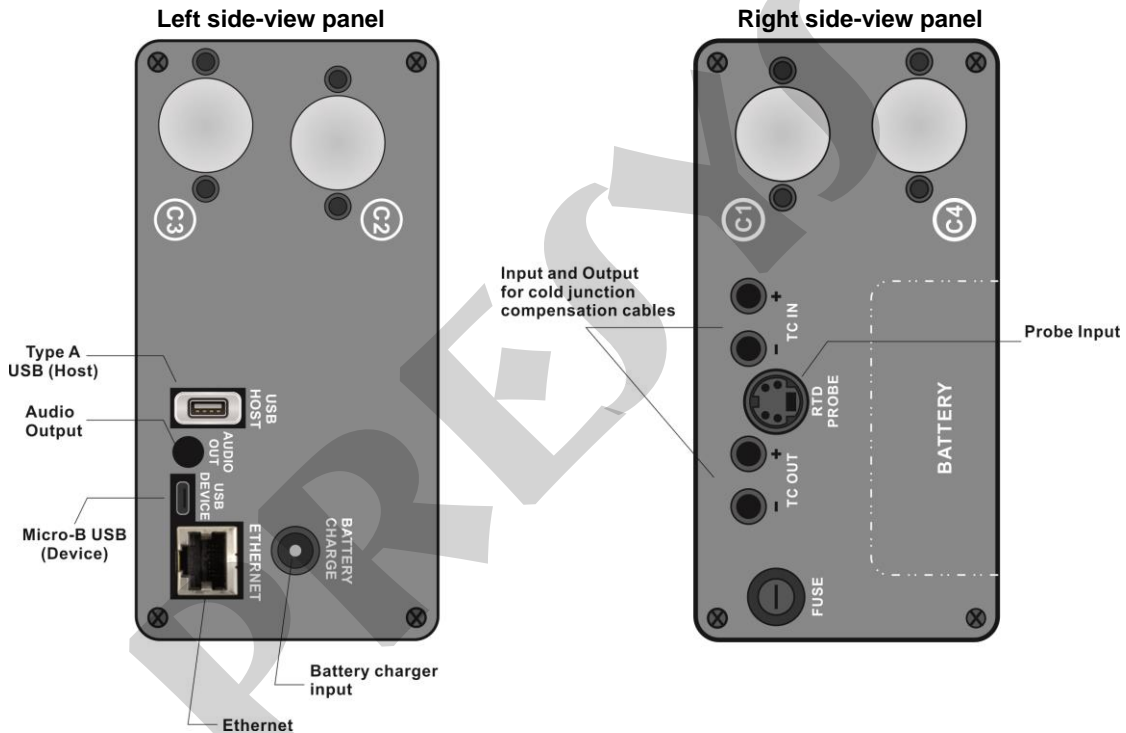

Fig. 02 - Side Panels – MCS-XV

How to Use the MCS-XV Carrying Case



Field use. Can be detached for workbench use.

Fig. 03 - How to Use the Carrying Case

Accessories: The bag has three compartments; one for accommodate the calibrator and the others to hold various accessories including test leads, adapter for connecting thermocouple wires, spare fuse, handles for transport and field use and technical manual.

Optional items: MCS-XV optional items are the accuracy temperature sensor (PROBE), the block of external cold junction compensation of high accuracy, pressure sensors and ISOPLAN[®] software. The optional items are described in specific manuals.

MCS-XV-RM (Rack Mounting Version)

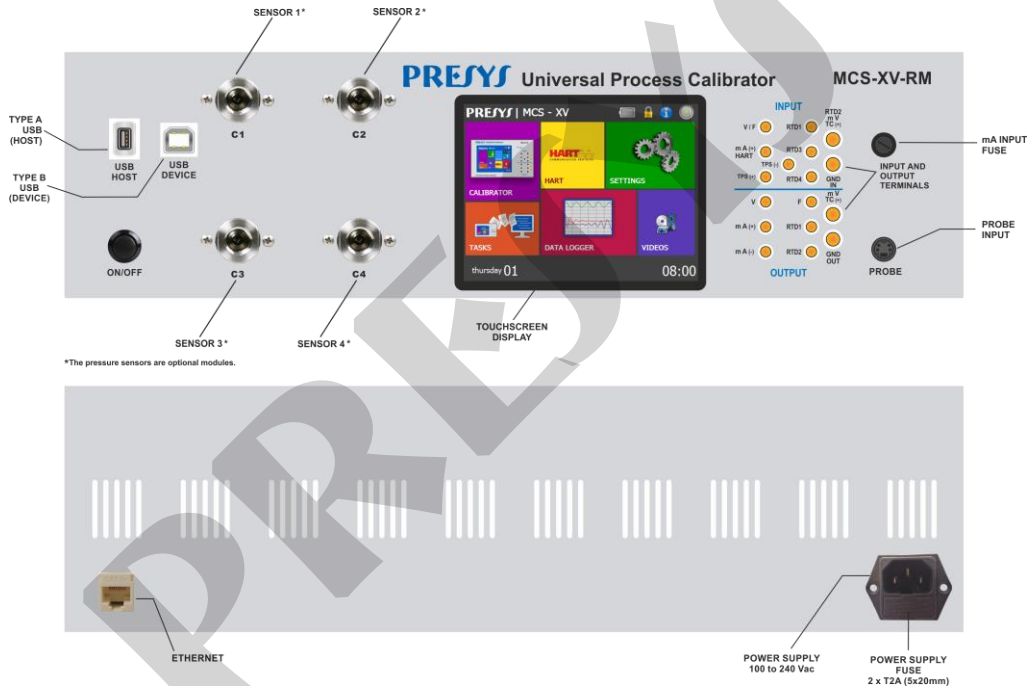

Fig. 04 – Front and Rear Panels – MCS-XV-RM

MCS-XV-DT (Desktop Version)

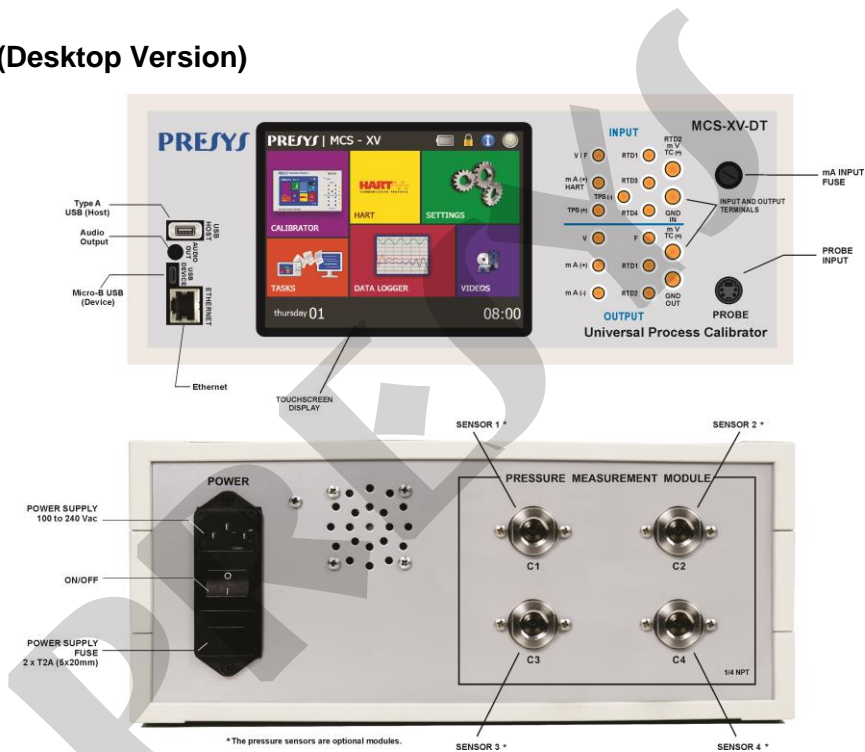

Fig. 05 – Front and Rear Panels – MCS-XV-DT

2.2. Battery and Charger (only for MCS-XV Portable Version)

The MCS-XV is supplied with rechargeable battery which enables up to 10 hours of continuous use. This autonomy is reduced according to the active functions. A battery charger that can be plugged into power supply from 100 to 240 Vac is included. The time for full charge is 3 hours.

The battery level is displayed in the main menu, as shown below.



Fig. 06 - Main Menu



-  Low Battery Level, charging required
-  Charged Battery
-  Charging Battery

Fig. 07 - Battery Levels

Clicking on the battery icon, the following screen is shown. This screen shows the battery power (in percent), current (positive value if the battery is charging, negative if it is not) and the estimated time of instrument autonomy based on the current consumption.



Fig. 08 - Battery Status

The charger provides the battery charge while it feeds the calibrator, thus permitting the calibrator to be used normally while the battery is being charged.

The batteries used by the calibrator are made of Lithium Polymer (Li-Po). This new technology for rechargeable batteries does not have the undesirable characteristics of memory effect as their preceding batteries made of Nickel Cadmium (Ni-Cd).

To prevent explosion or fire, use only the battery charger supplied by Presys. Do not short circuit or damage the battery.

2.3. Using MCS-XV: Basic Functions

When powered on, the calibrator goes through a self-test routine and shows the last adjustment date. In case of failure, it displays a message to indicate error; if that occurs, the instrument should be sent to manufacturer for repair.

After the self-test is completed, the display shows the main menu, as showed in **Figure 06**.

The main menu is divided into 06 functions:

CALIBRATOR – selects the input/output functions, see section 2.4.

HART[®] – optional module that allows communication with devices that have Hart[®] protocol, see section 2.5.

SETTINGS – general instrument settings, see section 3.

TASKS – performs calibrations automatically, see section 2.7.

DATA LOGGER – record measurements, enabling visualization in chart or table, see section 2.6.

VIDEOS – features videos made by Presys to assist in the use of the calibrator, and can also store videos made by the user, see section 2.8.

2.4. Calibrator

To select the input or output functions, from the main menu, press the **CALIBRATOR** button. The following screen is displayed.



Fig. 09 - Calibrator Functions

At the top is shown the channel 1 and at the bottom the channel 2. It can be changed in **Layout** option.

The icon  shows a **Quick Navigator**, with the options for Main Menu (**HOME**), **Data-Logger** and **Tasks**. Pressing **MENU**, there are options for the selection of display **Brightness**, **Layout** and **Memory Manager** (see

section 2.4.6). Furthermore, it brings information about the input/output configuration and IP address. Press **BACK** to return to Calibrator Mode or **HOME** to go to Main Menu.

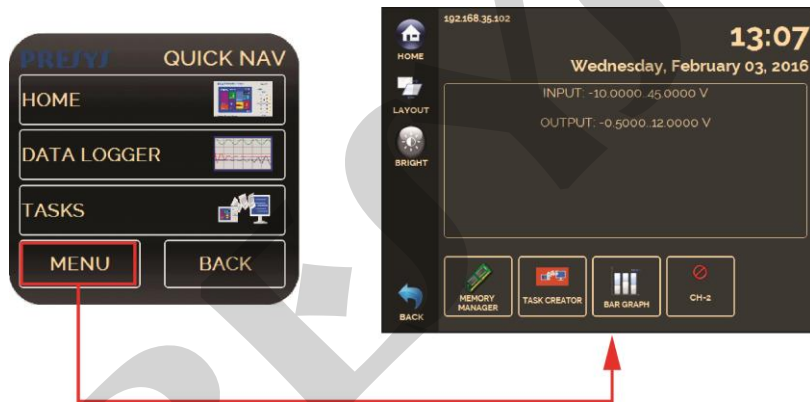



Fig. 10 - Quick Navigator and Secondary Menu

The channel 1 can be configured only as an input. The channel 2 can be configured as an output (default setting) or as PROBE or PRESSURE input. An example of channel 2 used as input is the calibration of a pressure transmitter, when you want to measure the transmitter current (mA input on CH-1) and the pressure (PRESSURE input in CH-2). To enable channel 2 as input, press the icon  > **MENU** and enable the CH-2 option. To enable channel 2 as output disable CH-2 option. To return to the Calibrator screen press the **BACK** button

To go to the main menu, press the icon , and the **HOME** button.

2.4.1. Measurement or Input Functions

a) Input Type Configuration

Press **Input CH-1**, select through the menu the type of signal to be measured and use the corresponding terminals (see **Figure 15 – Input Connections** or press the **HELP** button).

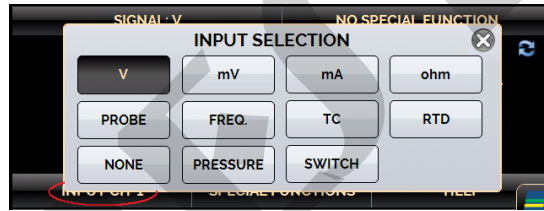

Fig. 11 - Input Type Selection

For **OHM** measurement, you should also select between 2, 3 or 4 wires options.

In **FREQ.** option, you can select the frequency or counter input. For counter input must also set the time (in seconds). If time is zero there is a continuous count of pulses received at the input. If the value is not zero, the count is done only during this time (window). The count starts immediately after pressing the **OK** button.

For **RTD** input, it should be chosen the type (standard table used), the number of lead wires (2, 3 or 4 wires) and the temperature scale (ITS-90 or IPTS-68). There is also the option to configure the Callendar-Van Dusen

coefficients of the sensor, selecting the option CVD and the desired curve in the list. To create new CVD coefficients, press **EDIT**, and **NEW** button. The curves appear in the created list as identified in TAG field.

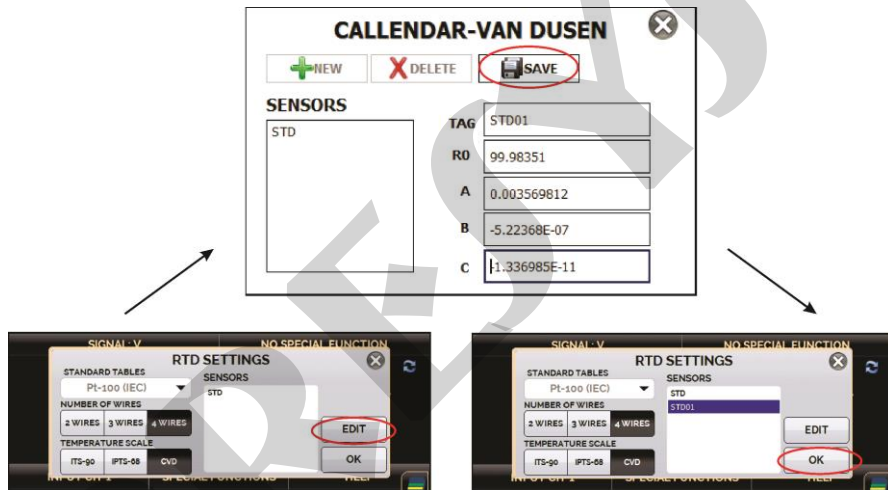

Fig. 12 - Calendar-Van Dusen coefficients configuration

PROBE refers to temperature measurement with an optional 4-wire Pt-100. Using the probe you can measure the temperature with high accuracy.

For **TC** (thermocouple) input, you must select the thermocouple type and the type of cold junction compensation (CJC): **Internal**, **Manual** or **Probe**. In **Internal** option, the compensation is done internally; In **Manual** you must set the value of the temperature of the cold junction to the calibrator. The **Probe** option corresponds to measuring the cold junction through a probe sensor or the external cold junction compensation block of high accuracy. One can use this block to accurately measure the cold junction of both input and output thermocouple. Connection details can be found in item d) of this same section.

When the input sensor breaking occur (RTD, resistance or probe) the display will show the burn-out warning identified by question marks illustrated below:



Fig. 13 - Burn-out Warning

PRESSURE option relates to pressure measurement with the MCS-XV through the optional pressure sensors. It should also select the pressure sensor to be read (C1, C2, C3 or C4).

Whenever the input signal is above or below the input ranges established in Section 1.2 - Specifications, the display indicates **OVER** or **UNDER**, respectively.

The **SWITCH** input is a measurement of continuity of an external contact connected to the input (between RTD1 and RTD4) of MCS-XV. When there is continuity, the input shows **CLOSED**, otherwise it shows **OPEN**.

The units of temperature and pressure can be changed by clicking on the engineering unit (°C, °F, psi, atm etc.) and selecting the desired option.

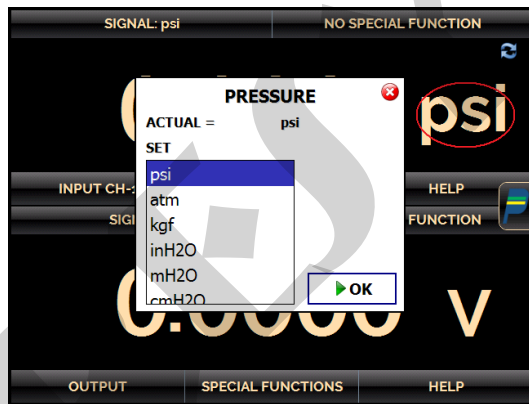

Fig. 14 - Selecting the Engineering Unit

The **NONE** option turns off the input function.

b) Input or Measurement Connections

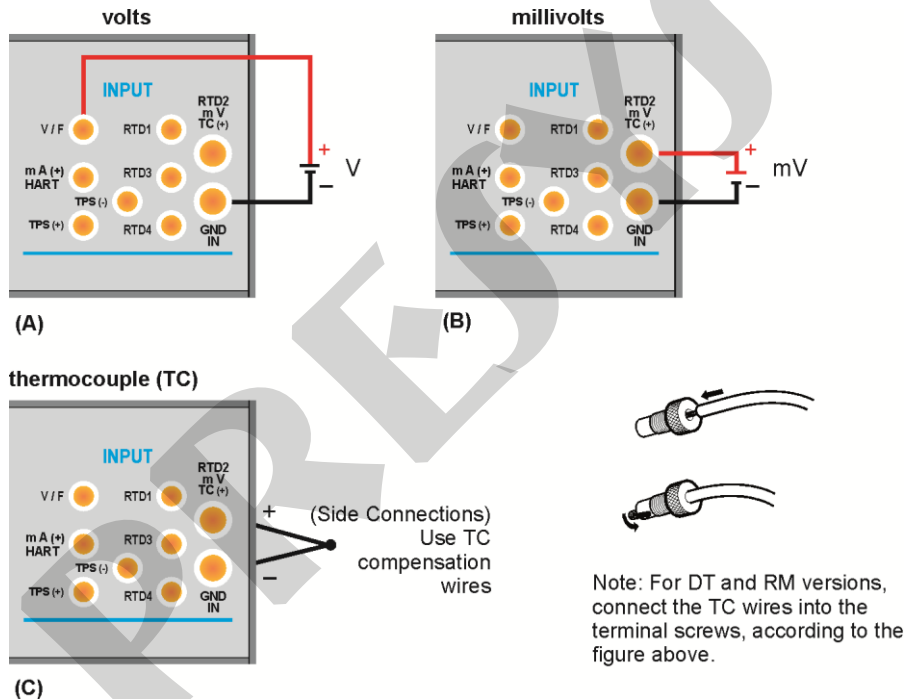
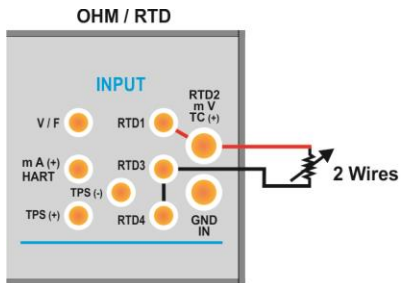
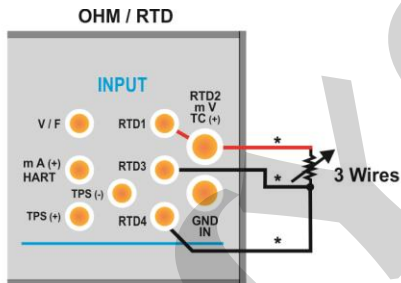

Fig. 15 - Input Connections



(D)



(E) * Use wires with the same length and gauge.

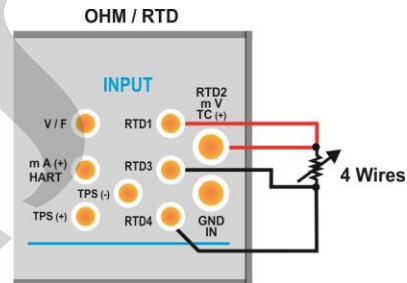

(F)

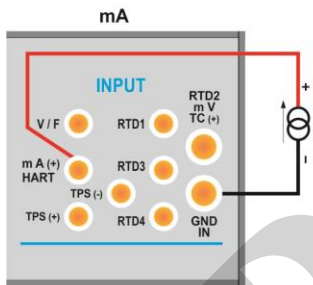

(G)

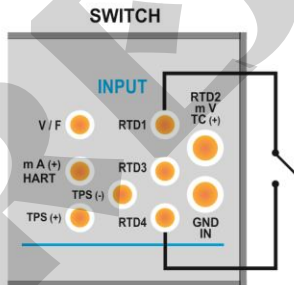

(H)

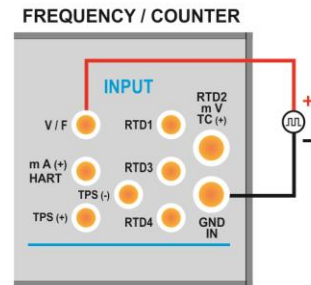

(I)

Fig. 15 - (Cont.) Input Connections

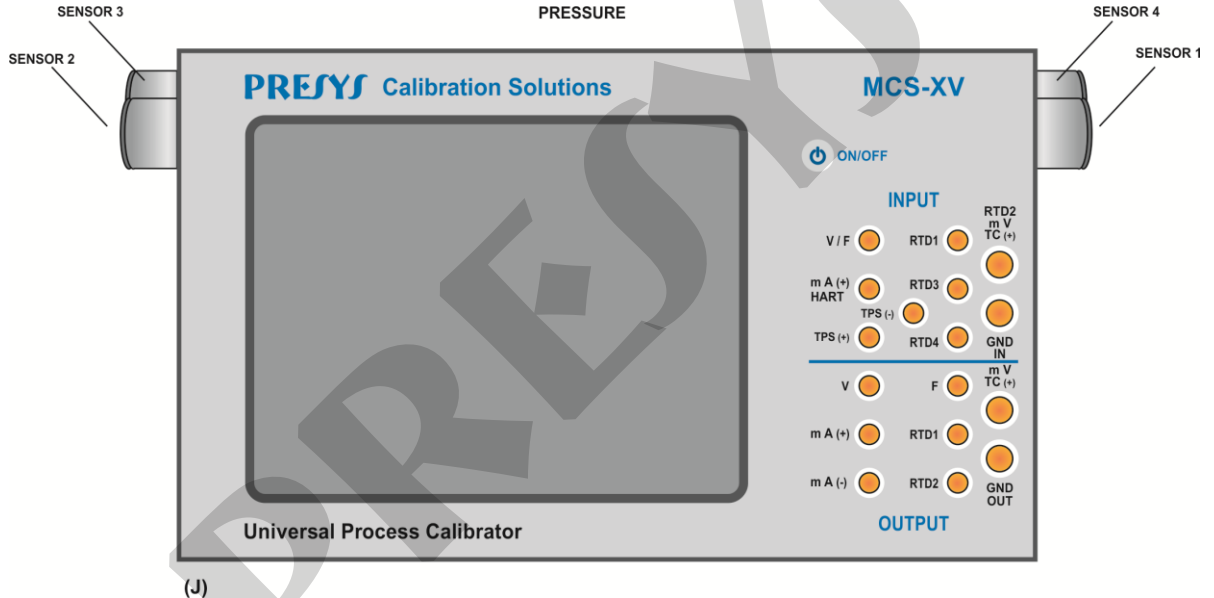

NOTE: For versions RM and DT, check the position of the pressure sensors in figures 04 and 05, respectively.

Fig. 15 - (Cont.) Input Connections

c) Probe Connection (optional)

Connect the **PROBE** to MCS-XV so that polarity identifications match. See figure below.

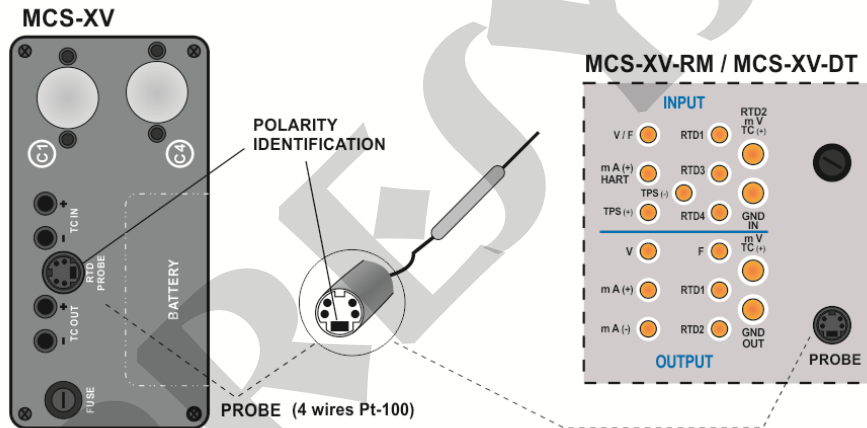

Fig. 16 - Probe Connection

d) High Accuracy External Cold Junction Compensation Block Connection – CJCB (optional)

Insert the high precision block in the TC input (IN) or TC output (OUT) terminals, and connect the cable which comes out of the block to calibrator Probe connector according to the same polarity described in item c) above. Depending on the block insertion in the TC input or in the TC output, the thermocouple connection will have its input or output cold junction given by the external compensation block. The input or output thermocouple connection must be made in the external compensation block itself. See the following figures:

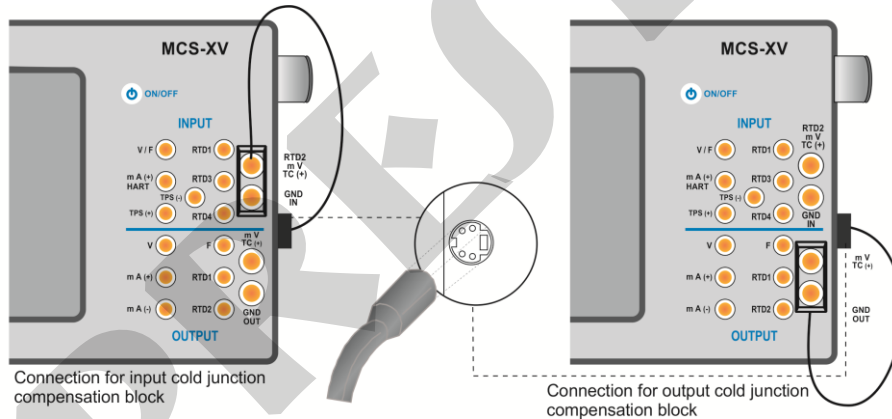

Fig. 17 - CJCB Connection

For an effective input or output cold junction measurement with the block, the **PROBE** option of thermocouple cold junction must be selected and enabled. In **CJC TYPE** select **PROBE**.

2.4.2. Generation or Output Functions

a) Output Type Configuration

Press the **OUTPUT** button, select through the menu the type of signal to be generated and use the corresponding terminals (see **Figure 20 - Output Connections** or press the **HELP** button).

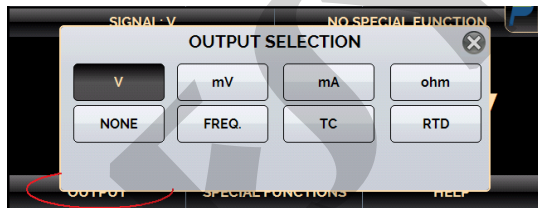





Fig. 18 - Output Type Selection

The **FREQ** option allows the selection of the frequency or pulse generation. For the frequency generation, it must be chosen between the bands of 100 Hz or 10000 Hz. It can also be adjusted the amplitude, which varies from 0 to 22 V. For the pulse generation (square wave) in addition to the amplitude and the number of pulses, one must provide the rate at which the pulses should be sent, given in Hz. The pulse sequence is sent as soon as OK is pressed.

For the **RTD** or **OHM** generation, the calibrator simulates electronically a resistance value, i.e., there is no resistor but an electronic circuit which behaves as a resistor. It was designed specifically with the purpose of simulating thermoresistances so that the calibrator can be connected to instruments such as indicators, transmitters, temperature controllers, with an excitation current within the range of 150 μA to 5 mA. For **OHM** generation, you should choose between the range of 400 Ω and 2,500 Ω .

For the thermocouple (TC) generation, you must choose the type of thermocouple and the type of cold junction compensation.

To change the value of the output, press on the number and type the desired value on the keyboard.

Another way to change the output value is to modify each digit separately in fixed steps. To do this, hold the output value for at least 3 seconds, choose the digit to be changed (the selected digit is indicated with arrows  and ) , and press the buttons  and  to change the setpoint. To exit this edit mode, hold down the output value for at least 3 seconds.

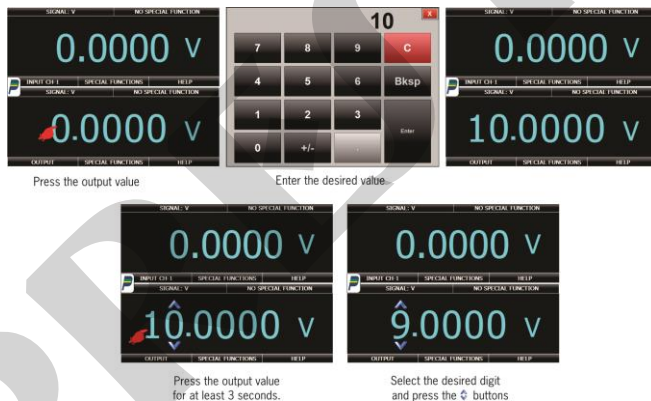

Fig. 19 - Changing the Output Value

The temperature units can be changed by clicking on the unit and selecting the desired option. The **NONE** option disables the output function.

b) Output or Generation Connections

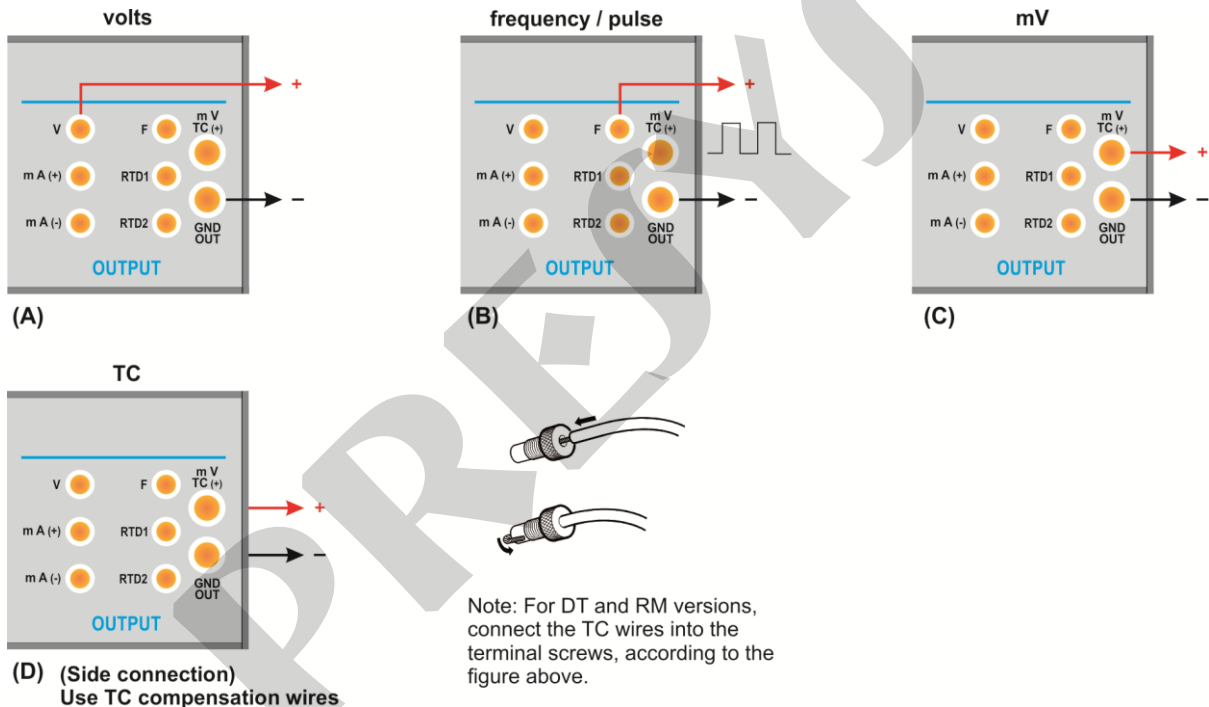
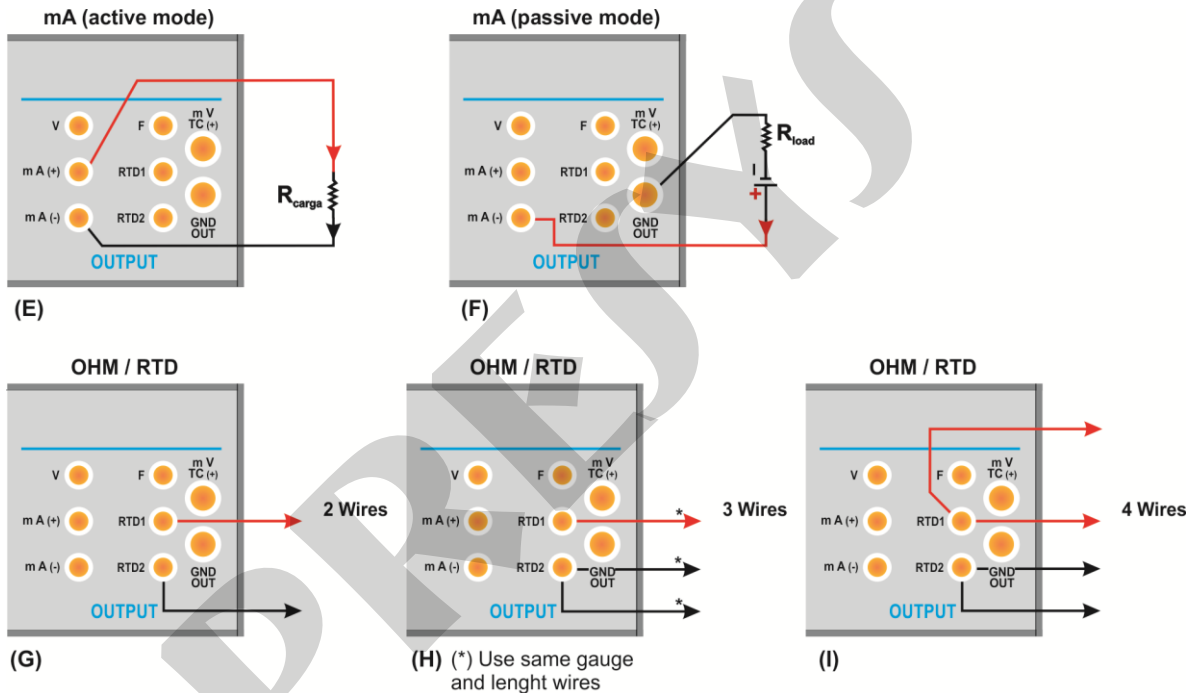

Fig. 20 - Output Connections



NOTE: There is no polarity for resistance output.

Fig. 20 - (Cont.) Output Connections

2.4.3. Available Power Supplies

The MCS-XV has two power supplies galvanically isolated: TPS and +22.5 Vdc at the output, both provided with short-circuit protection (current limited to 30 mA).

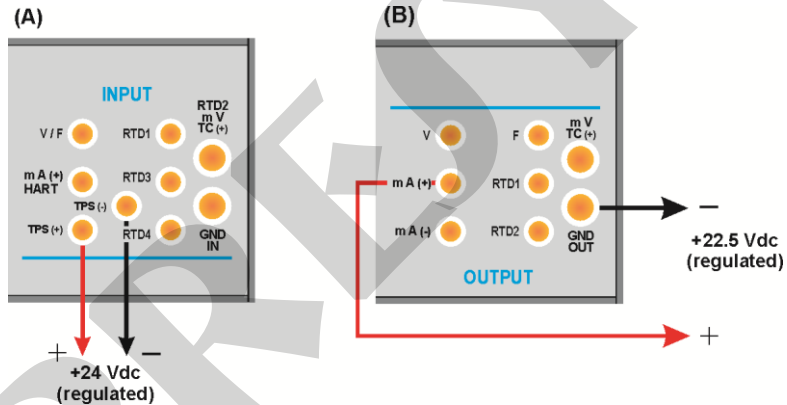

Fig. 21 - Power Supplies

2.4.4. Input Special Functions

Selecting **SPECIAL FUNCTIONS** in the input channel, the display will show:

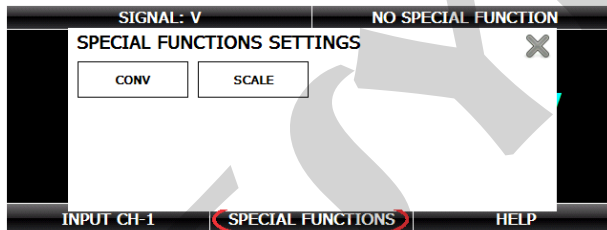

Fig. 22 - Input Special Functions

The selected special function will act on the previously selected input.

After selecting and configuring the special function, to enable it change to on the key status ON. To disable it change the key to OFF. To change the state of the key, just click on it.

When there is no active special function, the screen displays the message **NO SPECIAL FUNCTION** at the top.

a) SCALE Function

It establishes a linear relationship between the MCS-XV input signal and what is shown at the display, according to the graphic below:

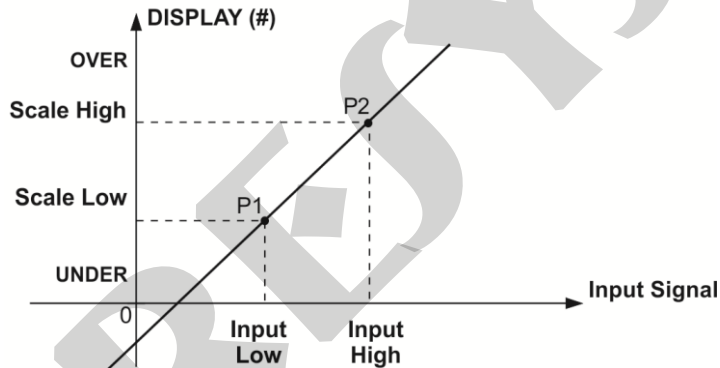

Fig. 23 - SCALE Function (LINEAR)

The scaled indication at the display (#) may represent any engineering unit, such as: m/s, m³/s, % etc. The number of decimals, up to 4, shown at the display may be configured.

The value for **Input High** must be necessarily higher than **Input Low**. On the other hand, **Scale High** and **Scale Low** may have any relationship between themselves: higher than, lower than or equal to, and they may have a signal before them. Thus direct or reverse relationships may be established.

The counter and the contact inputs cannot be scaled.

For the current input, a linear relationship may be established as it has been previously shown or it may be squared (**FLOW**) as illustrated below:

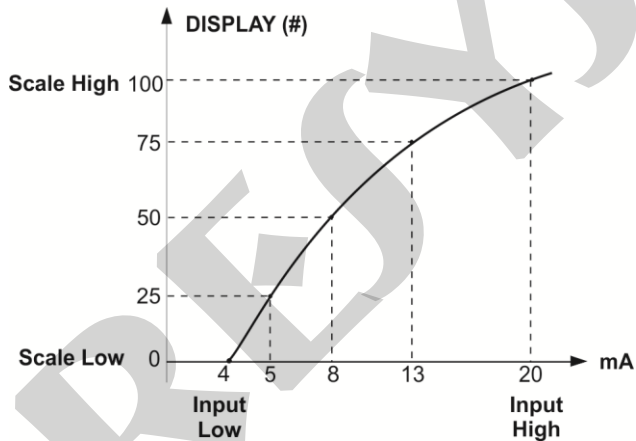

Fig. 24 - SCALE Function (FLOW)

b) CONV Function

By using the **CONV** function, the calibrator may convert any input signal into any output signal with galvanic isolation. It may, therefore, behave as a real transmitter.

Once the calibrator input and output have been selected, you must fill in the four parameters shown in the graphic below:

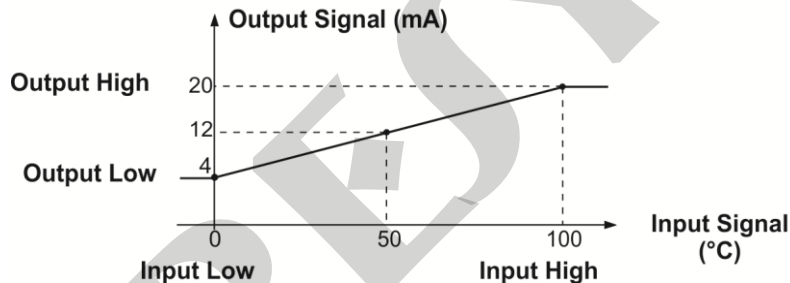

Fig. 25 - CONV Function

The value of **Output High** must always be higher than **Output Low**. **Input High** and **Input Low** parameters must never be equal. Thus any type of direct or reverse retransmission, from input to output, may be obtained.

2.4.5. Output Special Functions

Selecting **SPECIAL FUNCTIONS** in the output channel, the display will show:

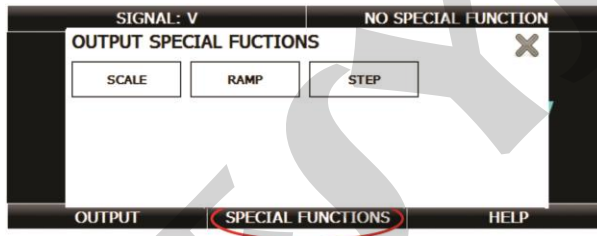

Fig. 26 - Output Special Functions

The selected special function will act on the previously selected output.

After selecting and configuring the special function, to enable it change to on the key status ON. To disable it change the key to OFF. To change the state of the key, just click on it.

When there is no active special function, the screen displays the message **NO SPECIAL FUNCTION** at the top.

a) RAMP Function

By using this programming, the MCS-XV output varies automatically, producing ramps and level marks which may be programmed to actuate once or continuously.



It must be entered the start and the end values of the range within which the output will vary (**MIN** and **MAX**), and the **TIME** value (in seconds) required for a complete ramp within the range. Another value that may be configured is how long it should dwell at the level mark (**WAIT**), i.e., the time during which the output remains constant between two ramps.

After setting up the special function and activate it (change the key  in special function), start the ramp pressing ► **PLAY**. The ramp runs continuously in accordance with the defined strategy (↑ ↓ ↑↓).

b) STEP Programming

The **STEP** programming makes the calibrator output vary in pre-defined steps. It is useful in calibrations where some scale points are verified; for example 0% - 25% - 50% - 75% - 100%.

To generate setpoints, you must set the minimum and maximum range points (**MIN** and **MAX**), the output percentage change for each step (%), and generate the list ( button).

There is also the option to manually add or delete any point to the list of setpoint values ( button: adds a point to the list,  button deletes the selected point,  button deletes all points).

If you want each step is achieved automatically after a preset time, you must set the **TIME** in seconds. In this situation the steps are generated automatically and continuously.

Activating the function and pressing **OK**, the output starts executing the **STEP** program, always starting from the beginning of the range. To move to the next step you must press ↑. Pressing ↓ it goes to the previous step. Pressing ►, the steps are automatically and continuously generated according to the set time.

c) SCALE Function

The scaling of the output from MCS-XV allows it to simulate the operation of a transmitter. In this case, the display scaled indication (#) simulates the transmitter input (which can be changed by pressing the number indicated on the display and entering the desired value), and as output signal it can have any of the signals generated by the MCS-XV (e.g. 4 to 20 mA).

SCALE output function relates the output signal generated by the MCS-XV with what is shown on the display as the example shown below.

The scaled indication at the display (#) may represent any engineering unit, such as: m/s, m³/s, % etc.

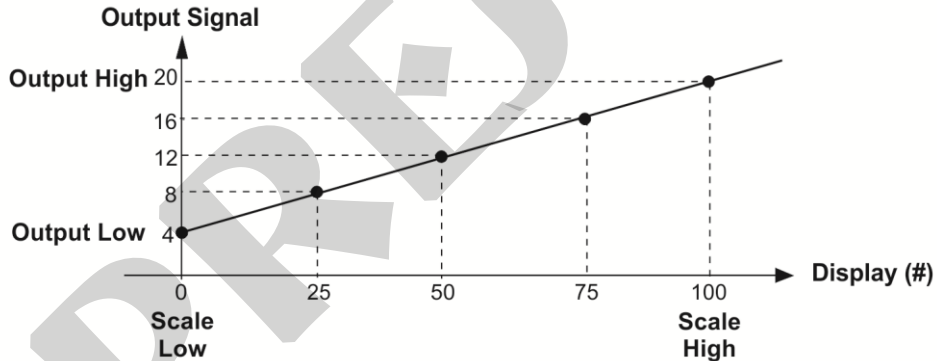

Fig. 27 - SCALE Function (LINEAR)

The number of decimals, up to 4, shown at the display may be configured.

The value for **Input High** must be necessarily higher than **Input Low**. On the other hand, **Scale High** and **Scale Low** may have any relationship between themselves, as long as they are not equal. Thus direct or reverse relationships may be established.

Any type of output can be scaled, except the pulse output.

For the current input, a linear relationship may be established as it has been previously shown or it may be squared (**FLOW**) as illustrated below:

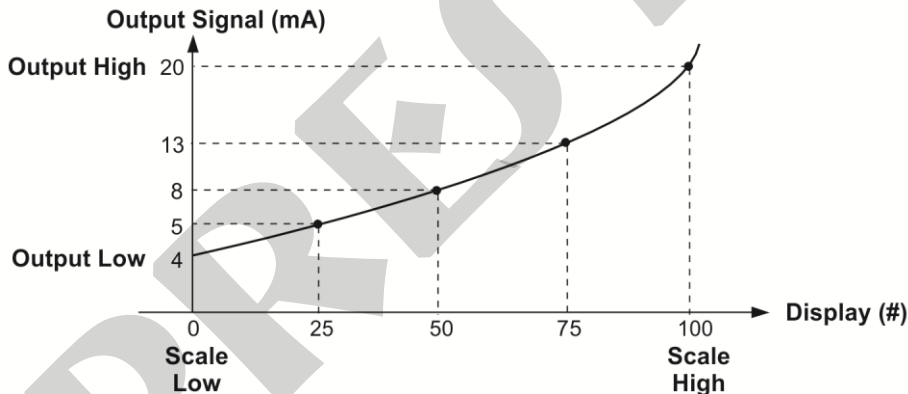



Fig. 28 - SCALE Function (FLOW)

2.4.6. Saving Current Configuration (Memory Manager)

The MCS-XV multicalibrator admits several special functions that may become of frequent use. In these situations, it is useful to store such settings in the instrument in order to save time.

After setting the desired calibration mode (input type, output type or special functions), press the icon  > **MENU**, and the button **MEMORY MANAGER**. On the option **CREATE NEW** can be given a name for this configuration and a description. Press the **SAVE** button.

The operation that was being performed by the MCS-XV shall be stored in memory identified by the name given to it. To use it again, even after the MCS-XV is turned off and on, select the name of the desired setting and press the **LOAD** button. The **SAVE AS DEFAULT** button sets the current configuration as the default configuration of the calibrator. Thus, every time the MCS-XV is turned on, this will be the initial configuration of the calibrator.

2.4.7. Calibration Examples

a) Calibration of a Temperature Transmitter (RTD Input and 4-20 mA Output)

Through the menus, you can configure the MCS-XV for mA input and output in RTD. The TPS, which means Transmitter Power Supply, is a source of 24 Vdc that provides power to the transmitter.

In the example, the connection of the RTD is made using three wires and being simulated by the MCS-XV. With this form of connection, there is no measurement error due to the resistance of the wires, since these have the same length and gauge.

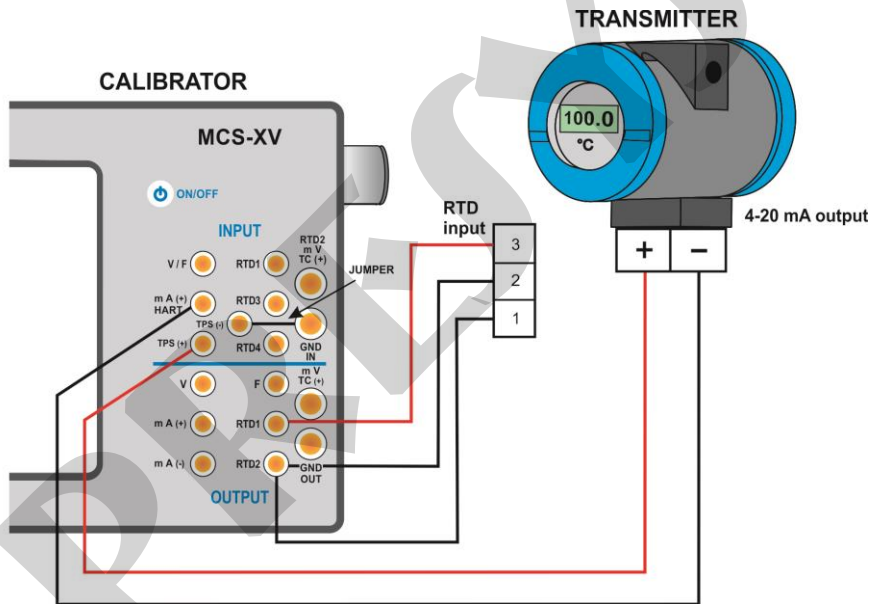

Fig. 29 - Calibration of a Temperature Transmitter 3-wire RTD Input

b) Calibration of a 4-wire Temperature Transmitter (110/220 Vac Power Supply - Thermocouple Input and 1-5 Vdc Output)

Setup the MCS-XV as volts output and TC input, and select the **TC** type. For the cold junction compensation, you can use compensating wires TC to connect the transmitter to the MCS-XV and choose the option of **Internal** cold junction compensation, or you can measure the temperature of the terminal of the transmitter and enter this value in the **Manual** option in the MCS-XV, thus eliminating the use of compensating wires.

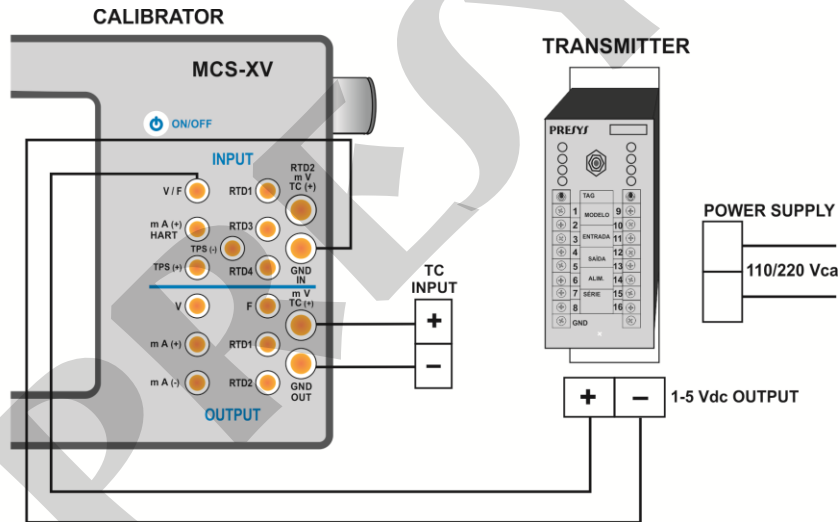



Fig. 30 - Calibration of a Temperature Transmitter (Thermocouple Input and 1-5 Vdc Output)

c) Pressure Transmitter Calibration

Use **TPS MCS-XV** source to power the two-wire transmitter 24 Vdc and connect the current as illustrated below. Select **mA** (current) in the Input menu of the CH-1 and **Pressure** Input on CH-2 menu. To enable channel 2 as input, press the icon  > **MENU** and enable the CH-2 option. To return to the Calibrator screen press the **BACK** button.

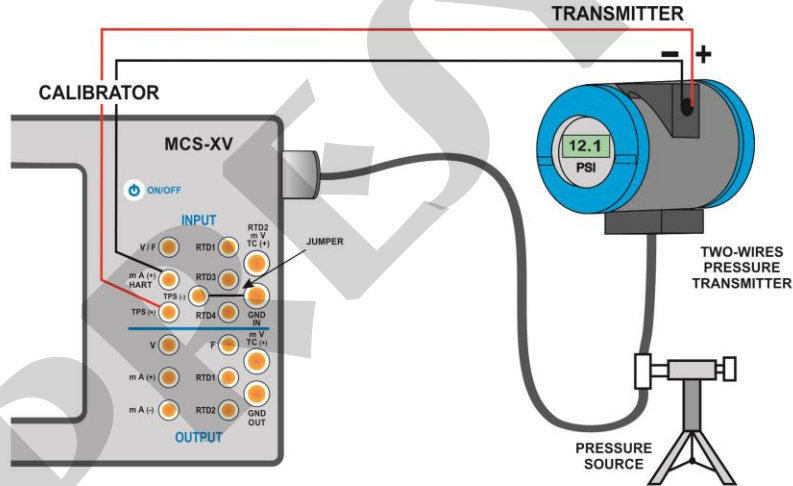

Fig. 31 - Pressure Transmitter Calibration

Readings of mA input can be scaled to pressure through the **SCALE** option (see item **2.4.4.a**). Thus the error between the input and the output of the pressure transmitter is easily calculated.

d) Pressure Switch Verification

Pressure switches are devices that receive a pressure signal and have relay alarm. The relay is activated whenever the pressure passes above or below a certain setpoint alarm.

Connect the pressure switch relay output to the switch input of MCS-XV, **RTD1** and **RTD4** terminals, and make the pneumatic connections as illustrated in the figure below:

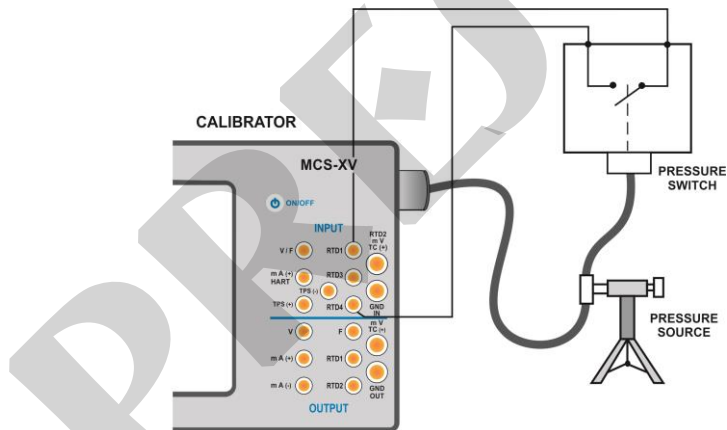

Fig. 32 - Pressure Switch Verification

Channel 2 must be disabled (select **NONE** as output type). On channel 1, select input **PRESSURE**, enable the option **PRESSURE SWITCH** and select the corresponding sensor.

Channel 1 starts to show the pressure measurement and the contact status (open or closed).

Press **RUN** to start the test.

Vary the pressure manually. The instant the relay changes position, it is shown on the display the alarm setpoint pressure switch, so the change from open to closed or from closed to open.

2.5. HART®

The MCS-XV can be used to read and set parameters in devices that have HART® Communication Protocol. The HART® Protocol allows digital communication between master (in this case, the MCS-XV) and the slave (field instrument) superimposed on the 4-20 mA analog signal. To access this function from the main menu, select the **HART®** option.

The HART® Communication of MCS-XV is an optional module. The calibrator has three versions: **NH** (without HART® Communication), **CH** (HART® Calibrator) and **FH** (Full-HART® configurator with DD library).

The **CH** option has basic and universal commands for HART® communication (zero, span, trim mA etc.) that allow you to adjust the range of the instrument, monitoring the primary variable, current adjustment etc. The **FH** option, in addition to basic and universal commands, is provided with the DD library (Device Description) from *FieldComm Group* and allows the setting of specific parameters of each instrument.

The following description is valid for **CH** and **FH** options.

2.5.1. HART® Connections

When selecting HART® from the main menu the **mA INPUT + HART** and **ONLY HART (INCLUDING NETWORK)** options are shown. Can also be enabled or not the internal resistor (250 Ω). The option must be chosen according to the type of connection to be made.

a) mA INPUT + HART®

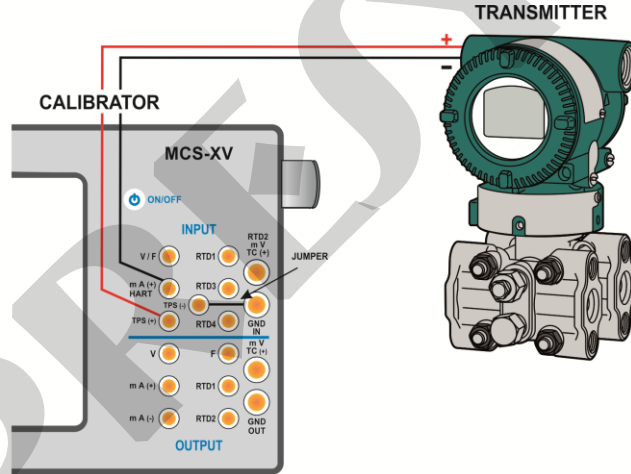

**Fig. 33 - Transmitter Powered by the Calibrator Itself (TPS)
mA INPUT + HART® (Internal Resistor Enabled)**

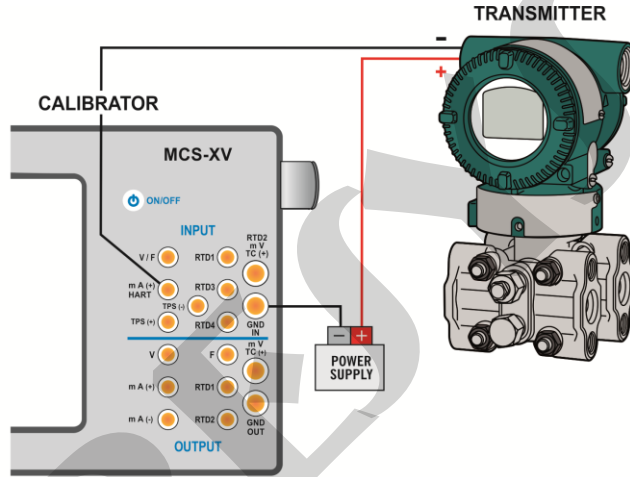

**Fig. 34 - Transmitter Powered by an External Power Supply
mA INPUT + HART® (Internal Resistor Enabled)**

To the connections shown in **Figure 33** and **Figure 34**, use the **mA INPUT + HART®** option and **INTERNAL RESISTOR** enabled. In this mode, the 250 Ω resistor is activated internally in series with the calibrator mA input. The calibrator can measure current from the transmitter and also read and set parameters via HART®. If the internal resistor is not enabled, an external resistor of at least 150 Ω must be inserted in series with the mA input. To power the transmitter, can be used the **TPS MCS-XV** source (**Figure 33**) or an external source (**Figure 34**).

b) ONLY HART (INCLUDING NETWORK)

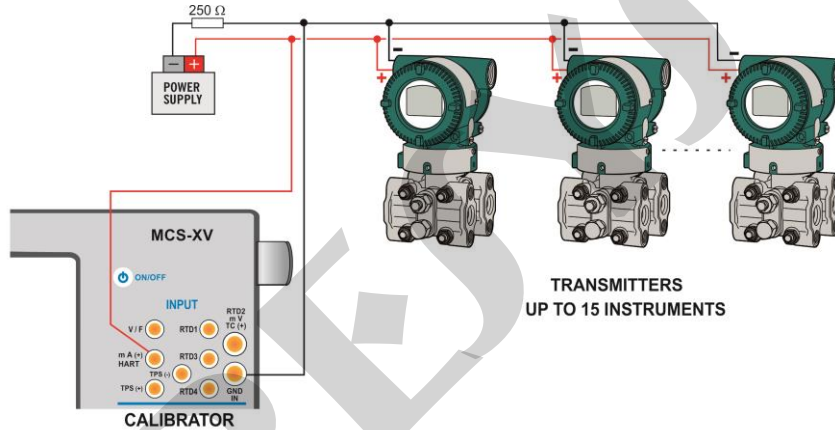

Fig. 35 - ONLY HART®

IMPORTANT: Before connecting the calibrator to the transmitter as shown above, ensure that the mA Input is not selected in the MCS-XV (enter in the Calibrator menu, and select any CH-1 Input other than mA or none).

For the connection shown in **Figure 35**, use the option **ONLY HART®**. In this mode, the internal resistor and the mA input are disabled. The HART® resistor (at least 250 Ω) must be externally inserted in series with the power source and the transmitter. In this case, the calibrator does not perform the measurement of the transmitter current, but can read and configure its parameters via HART®.

2.5.2. Starting Communication

Entering the **HART[®]** menu, the following screen is shown. Enabling the **HART[®] CONFIGURATOR** option (only for **FH** version), you have access to the Full-Hart software (DD library) with all device parameters. Disabling this option, the **CH** software is launched with basic and universal commands for HART[®] communication (zero, span, trim mA etc.).

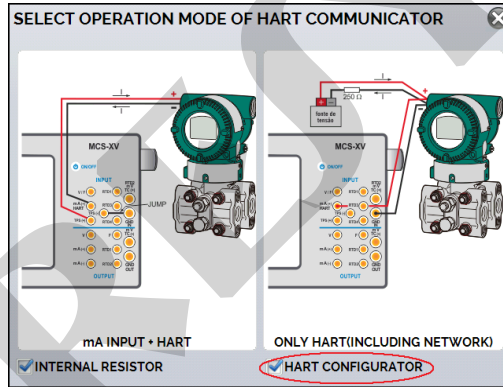

Fig. 36 - Choosing between CH or FH option

Then, define the Internal Resistor (250Ω) and the configuration of HART[®] connection type (**mA input + HART[®]** or **ONLY HART[®]**).

For the **CH** option, insert the **ADDRESS** of the HART[®] device and press the **CONNECT** button. If the instrument address is unknown, can be used the **SEARCH** button, which will search the device in the address range from 0 to 15. For the **FH** option, the device is automatically found.

Up to 15 devices on a HART network (addresses 1-15) are allowed. In connection with a single field instrument with poll address 0 and **mA INPUT + HART[®]** connection, the primary variable can be read either in analog (4-20 mA) and digital form (HART[®]). In networking, the only way to read the primary variable is digitally (**ONLY HART[®]**).

2.5.3. Adjusting the Measurement Range of a HART[®] Transmitter (CH Option)

When connecting, appears in the **DEVICE INFO** tab data identifying the instrument, such as TAG, manufacturer, description, message, date, measuring range and input filter (damping). Some of these parameters can be changed in the **DEFAULT SETTINGS**.

In **DEVICE INFO** tab, the **MIN** and **MAX** fields indicate the measuring range of the HART[®] transmitter. For PV (primary variable) equal to the MIN value, the transmitter should generate 4 mA. For PV (primary variable) equal to MAX value, the transmitter should generate 20 mA. The maximum allowable range of the transmitter is shown just above (**RANGE ...**). To edit the range of the transmitter, just change the MIN and MAX values and press the **SAVE RANGE** button.

On this screen you can also edit the unit of the primary variable and the input filter (damping).

HART COMMUNICATOR

ADDRESS

SEARCH

NEW ADDRESS:

GENERAL INFO

MANUFACTURER:

REVISION:

TAG:

DATE:

MESSAGE:

DESCRIPTOR:

RANGE INFO

Range: -200 .. 850 °C Transmitter measuring range

MIN:

MAX:

UNIT: °C

FILTER(S):

DEVICE INFO | DEFAULT SETTINGS | MONITORING

Fig. 37 - Adjusting the measuring range of the HART[®] transmitter

2.5.4. Adjusting the Measurement Range of a HART[®] Transmitter with Reference (CH Option)

The range of the transmitter can also be adjusted generating the minimum and maximum values of the desired range in the transmitter input and adjusting these values as minimum and maximum (set by reference).

Select Input mA and press the **HART[®]** button. Connect the transmitter to the mA input. The reference value inserted in the transmitter input can be generated or measured by the MCS-XV itself. For this, before connecting the HART instrument, from the main menu, select **CALIBRATOR**, and select on **Channel 2** the type of desired signal.





For instance, to adjust the range of a Pt-100 temperature transmitter, select in **CALIBRATOR** menu **RTD Pt-100** as output and connect it to the transmitter input. For a pressure transmitter, channel 2 must be set as **PRESSURE** input and the pressure must be generated manually with a pump, e.g., and connected to the MCS-XV. To enable channel 2 as input, press the icon  > **MENU** and enable the **CH-2** option. To enable channel 2 as output disable **CH-2** option. To return to the calibrator screen press the **BACK** button. The signal measurement or generation of **CH-2** will work as the standard value for the adjustment range of the instrument.



Fig. 38 - Quick Hart[®] Adjustment with Reference

Generate the signal to the transmitter input corresponding to the lower range value and press the  button. Transmitter will generate 4 mA to this value. Generate the signal to the transmitter input corresponding to the upper range value and press  button. Transmitter will generate 20 mA for this value.

Another way of doing the range adjustment by reference is entering in the HART option. Back to the main menu by pressing the icon  and the **HOME** button. Select **HART[®]**, set the connection type, address and then press **CONNECT**.

For this setting, select the **MONITORING** tab. In this screen are shown the value of the primary variable (PV) read by HART® (digital), the current that the transmitter wants to generate (**AO - DIGITAL OUTPUT**), and the current measured by the MCS-XV (**ANALOGIC READ**).

To adjust the range of the transmitter, generate the signal to the transmitter input corresponding to the lower range value and press the ↓ **Inf Range** button. Transmitter will generate 4 mA to this value. Generate the signal to the transmitter input corresponding to the upper range value and press ↑ **Sup. Range**. Transmitter will generate 20 mA for this value.

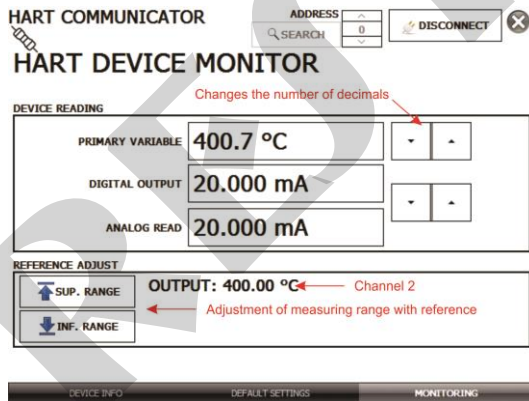

Fig. 39 - Adjusting the Measuring Range of the HART® Transmitter with Reference

In **MONITORING** screen, beyond stating the primary variable PV and the transmitter current, is shown the measured or generated value by the MCS-XV in **CH-2**. If the **CH-2** is configured as an output, click on the number to change the value of output.

2.5.5. Checking / Adjusting HART[®] Transmitter mA Output (CH Option)

In **DEFAULT SETTINGS** tab can be adjusted the output current of the HART[®] transmitter (output trim) according to current measured by MCS-XV. You can make this adjustment only when the MCS-XV is connected to a single transmitter with address 0, in the **mA INPUT + HART[®]** option of connection, since the calibrator needs to measure the current to make the adjustment.

Before performing the adjustment, a transmitter output current check can be performed by pressing the **CHECK** button. The transmitter will generate fixed current (4, 8, 12, 16, 20 mA) and the calibrator will show the measured values for each point.

To adjust automatically, simply press the **AUTO** button. The calibrator will send the command to the transmitter to generate 4 and 20 mA (fix), make the measurement of these points, and adjust the output (trim). The adjustment is completed when **D/A Adjustment Completed** message appears.

The **LEAD TIME** field sets the time (in seconds) of each point stabilization time.

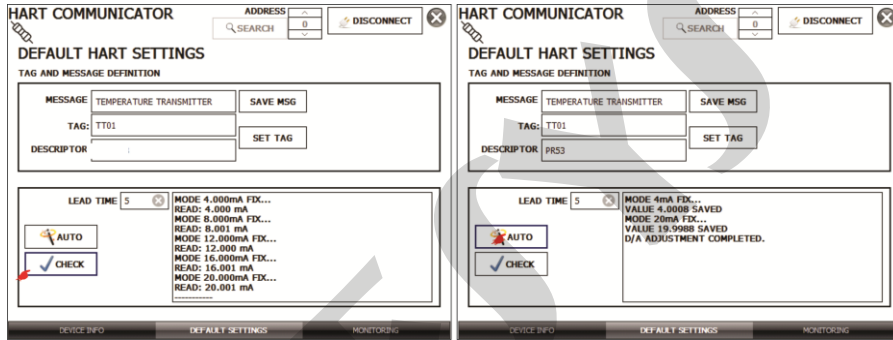

Fig. 40 - Checking / Adjusting the mA HART® Transmitter Output

2.5.6. Full-Hart Configurator (FH Option)

If the **HART CONFIGURATOR** option is enabled the **FH** Software is launched. For this option, the device is automatically found and the screen shows the basic, universal and specific parameters (DD library).

To start the HART configurator you should wait the MCS-XV to read the device parameters. The MCS-XV will show the message **Reading device information. Please wait...** After connecting, at the bottom of the screen it shows the TAG, connected instrument model and the DD file (Device Description) used.

You can open the instrument configuration tree, located on the left side of the screen. This configuration tree changes according to the instrument, as each HART® transmitter has its specific commands.

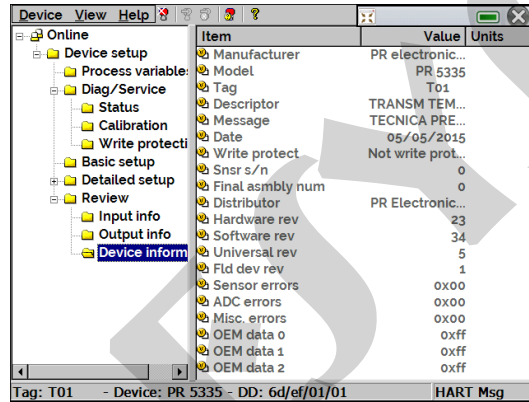





Fig. 41 - Device Parameters

Double-click the parameter you want to change and edit the desired value.

Parameters identified with the icon  have methods. To change them, just double-click the parameter and follow the steps shown.

For other parameters, after editing the value the field becomes yellow, indicating that it has been changed, but not saved in the transmitter yet. To confirm click on the button . To cancel, press .

To view the MCS-XV mA input value or change the output setpoint, press the  button:

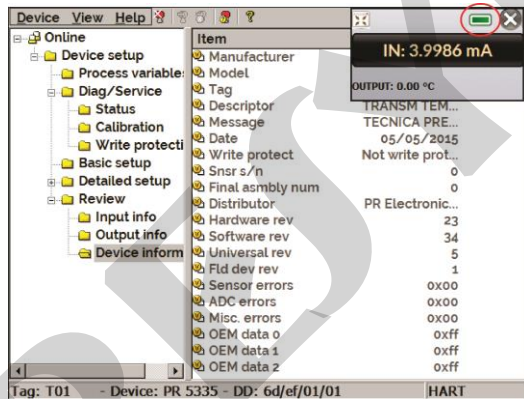

Fig. 42 - MCS-XV Input and Output Values

To view the device status, press the **VIEW** menu and **DEVICE CONDITION**:

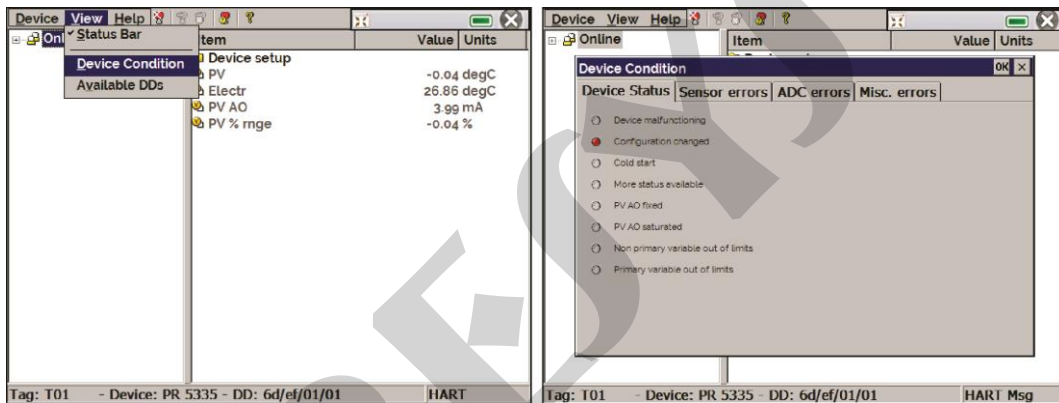

Fig. 43 - Device Condition

To save all the configuration of a HART[®] instrument connected to the MCS-XV, can be used the **Document Device** function, from the **Device** menu. This function is useful to save the configuration of an instrument for later download to another instrument of the same model, or else just to make a backup of the settings made.

Press **Device** → **Document Device**, fill in the **File Name** blank and press **Save Device Config**. Optionally, it can be given a description of the configuration file in the **Notes** blank.

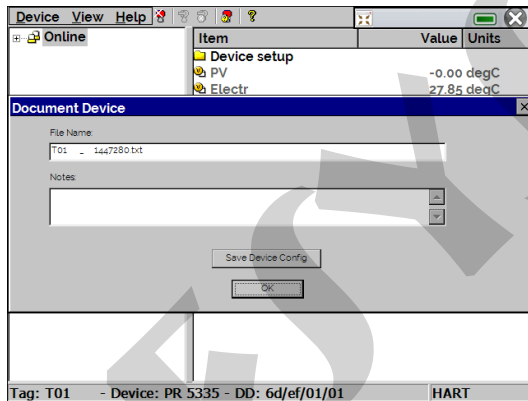



Fig. 44 - Saving a Device Configuration

When you want to download a saved configuration for an instrument, access the menu **Device** → **Download / View**. To select the desired configuration file, double-click it.

Press the **Write** button to download the configuration file for the connected instrument. Before the instrument is fully configured, some confirmation messages will be displayed. To cancel, press **X**. To proceed, press **OK**. At the end of configuration, the **Configuration Write Complete** message appears.

2.6. Data Logger

The MCS-XV allows you to record series of measurements over time to display data in chart or table format. Select **CALIBRATOR** from the main menu and select the desired type of signal on channel 1 and channel 2.

Press the icon  and select **DATA LOGGER**. The calibrator automatically starts the measurements and displays each measured point on the chart.

For measurements to be saved, you must press the **REC** button (see **Figure 45**). With this option selected, all points (measurement and time) are saved in an internal file in MCS-XV, which can be used to generate a table or chart.

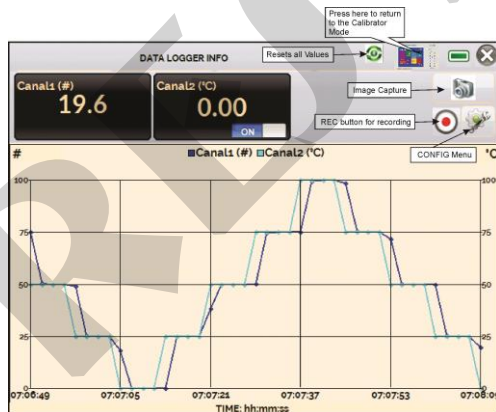

Fig. 45 - Data Logger

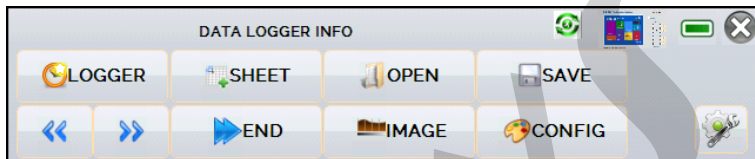



Fig. 46 - Data-Logger Configuration Menu

Entering in the Configuration Menu, in **CONFIG** option, you can edit the background color of the chart, color and line thickness, sampling rate (in seconds) and set the x (time) and y (measurements) axis of the chart.

Recording can also be programmed to start at a certain date and time in the **LOGGER** option. Just set the start time and end time of recording. During the defined range, the measured points are saved in an internal file in MCS-XV.

To view a saved file press the **OPEN** button, select the desired file, and press **LOAD**. The file name contains the date and time of the measurements.

The **SHEET** button allows the visualization of data in table format, with the date and time of the measurement and the measured values.

If the user wants to export the current data to a .csv file that can be opened in spreadsheet softwares, press the **SAVE** button and indicate the name and where it will be saved. The button  saves the current screen image as a .png file. All saved screens can be viewed in the **IMAGE** menu. These files are saved in the internal SD card of the calibrator. If a USB Pen Drive is connected to MCS-XV, you can choose between saving in the internal SD card or the Pen Drive.

To access the files saved in the internal SD card of the calibrator, connect the USB cable to the computer (type A USB) and to the MCS-XV (Type B USB - Device, see **Figures 02, 04 and 05**, portable, RM and DT versions, respectively).

2.7. Automatic Tasks

In MCS-XV, can be created and performed automatic calibration tasks. This option can be used to generate calibration work orders of transmitters and indicators.

2.7.1. Creating Tasks

To create tasks from the main menu, select **CALIBRATOR**. Select the desired type of signal on channel 1 and channel 2. For example, to calibrate a thermocouple temperature transmitter, select TC output (which will be connected to the transmitter input) and mA input (which will be connected to the current output of the transmitter). For a voltage indicator, e.g., selected output V (which is connected to the indicator input) and NONE for the input (the instrument reading will be inserted manually).

Press the  icon, and select **TASKS** → **CREATE NEW TASK**.

Fill at least the serial number of the instrument to be calibrated, instrument TAG, stabilization time for each point (waiting time in seconds) and the maximum error allowed for the instrument to be calibrated (in % of the span, reading or full scale).

The screenshot shows a dialog box titled "OPEN TEMPLATE". It contains the following fields and values:

CREATED BY	John A.		
MANUFACTURER	Presys		
MODEL	RTD Transmitter		
MESSAGE	Connect the transmitter to the MCS-XV		
PLANT	LAB		
SERIAL N.	001.0115	WAITING TIME(S)	10
TAG	TT01	MAX ERROR (%)	0.1
ERROR	SPAN		

At the bottom of the dialog, there are three tabs: "Task info", "AsFound/ AsLeft", and "Review and Save".

Fig. 47 - Task Information

Go to the **As Found/ As Left** tab. Add each point to be generated by the MCS-XV and the expected value for the instrument under calibration both **As found** (calibration done before adjustment) and **As left** (calibration done after adjustment) values. Points can also be generated with the help of **AUTO** button. By pressing this button, simply enter the maximum and minimum values of the calibration range and the amount of points that it will generate a list of points considering the same steps and a linear scale. Also fill the number of repetitions (**REP**) of the readings, and the calibration strategy (initial to the final point ↑, final to the initial point ↓, etc.). The **REP** field in the **As found** calibration can be filled with the value 0 (the task will contain only **As left** calibration). The minimum value for the **REP** field in the **As left** calibration is 1.

AS FOUND

EXPECTED 4.0000 mA (IN) 0.00 4.0000

POINT 0.00 °C (OUT) 25.00 8.0000

REP. 1 AUTO 50.00 12.0000

STRATEGY 75.00 16.0000

100.00 20.0000

AS LEFT

EXPECTED 4.0000 mA (IN) 0.00 4.0000

POINT 0.00 °C (OUT) 25.00 8.0000

REP. 1 AUTO 50.00 12.0000

STRATEGY 75.00 16.0000

100.00 20.0000

RANGE 4.0000 .. 20.0000 mA (IN)

Task info AsFound/AsLeft Review and Save

Fig. 48 - Task Points and Strategy

Go to the **Review and Save** bar. Choose an identification name/number for your task. If you want to save the model of this task for later use in creating other tasks, press **SAVE TEMPLATE** and give a name for it. When you want to open this model again, open the task creation screen and press **OPEN TEMPLATE** in **Task info** tab.

Click on **CREATE** button to create it. The task is now saved in the calibrator.

The screenshot displays a software interface for task identification. It is divided into two main sections: 'TASK DETAILS' and 'IDENTIFICATION'. The 'TASK DETAILS' section contains the following information: 'CREATED IN: 03/02/2016', 'INSTRUMENT DETAILS:', 'TAG: TT01', 'SERIAL NUMBER: 001.01.15', 'MODEL: RTD Transmitter', 'MANUFACTURER: Presys', 'INPUT RANGE: 0 TO 100 °C (RTD)', 'OUTPUT RANGE: 4 TO 20 mA', 'MAX ERROR = 0.1% SPAN(SPAN = 16 mA)', and 'LEAD TIME: 10 SECONDS'. The 'IDENTIFICATION' section features a text input field containing 'wo-001' with a clear button (X) on the right. Below the input field are two buttons: 'SAVE TEMPLATE' and 'CREATE'. At the bottom of the screen, there is a dark navigation bar with three options: 'Task info', 'AsFound/AsLeft', and 'Review and Save'.

Section	Field/Item	Value
TASK DETAILS	CREATED IN:	03/02/2016
	INSTRUMENT DETAILS:	
	TAG:	TT01
	SERIAL NUMBER:	001.01.15
	MODEL:	RTD Transmitter
	MANUFACTURER:	Presys
	INPUT RANGE:	0 TO 100 °C (RTD)
	OUTPUT RANGE:	4 TO 20 mA
	MAX ERROR:	0.1% SPAN(SPAN = 16 mA)
	LEAD TIME:	10 SECONDS
IDENTIFICATION	Input Field	wo-001
	Buttons	SAVE TEMPLATE, CREATE
Navigation Bar		
Task info	AsFound/AsLeft	Review and Save

Fig. 49 - Identifying the task

2.7.2. Performing Tasks

To perform a task created from the main menu select **TASKS** → **EXPLORE TASKS**. A list identifying the created work orders that have not been performed yet (● **WAITING**) is shown. Select the desired task and press **OK**. Make the necessary connections between the calibrator and the instrument to be calibrated and press **START**.

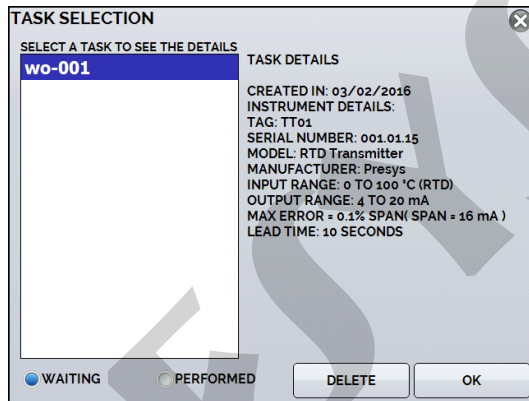

Fig. 50 - Exploring Tasks

The MCS-XV automatically starts to do the calibration generating setpoints registered on task and doing the reading of the instrument to be calibrated. If it was selected the **NONE** input, for each generated point the calibrator requires the value read by the instrument. The result will be displayed on the screen, and a progress bar is displayed to indicate the calibration remaining time. At the end of the calibration, a report is shown with the generated values, the obtained values, the expected values, and the error. If the error is higher than the registered value for the task, the line appears in red.

The first time that a task is performed, it will be saved as **As found** (before adjustment). If it runs again, it will be saved as **As left** (after adjustment). The results are saved in the calibrator and can be viewed at any time.

2.7.3. Viewing Results

Once a task has been performed, it remains saved in the calibrator.

To view the results of a calibration in MCS-XV, in the main menu select **TASKS**.

Enable the option **PERFORMED**. The list will show only the tasks that have been performed. Select the desired work order and press **OK**. On screen, the report with the calibration points, the obtained values, expected values and the errors will be shown. If the error is higher than the value registered for the task, the line appears in red.

AS FOUND PERFORMED BY: John A.				
POINT	EXPECTED	OBTAINED	ABS. ERR.	SPAN ERR.
0.00 °C	4.0000 mA	3.9955 mA	-0.0045 mA	-0.028%
25.00 °C	8.0000 mA	7.9907 mA	-0.0093 mA	-0.058%
50.00 °C	12.0000 mA	11.9897 mA	-0.0103 mA	-0.064%
75.00 °C	16.0000 mA	15.9934 mA	-0.0066 mA	-0.041%
100.00 °C	20.0000 mA	19.9968 mA	-0.0032 mA	-0.020%
AS LEFT PERFORMED BY: John A.				
POINT	EXPECTED	OBTAINED	ABS. ERR.	SPAN ERR.
0.00 °C	4.0000 mA	4.0001 mA	0.0001 mA	0.001%
25.00 °C	8.0000 mA	7.9949 mA	-0.0051 mA	-0.032%
50.00 °C	12.0000 mA	11.9911 mA	-0.0089 mA	-0.056%
75.00 °C	16.0000 mA	15.9932 mA	-0.0068 mA	-0.042%
100.00 °C	20.0000 mA	19.9957 mA	-0.0043 mA	-0.027%
100.00 °C	20.0000 mA	19.9983 mA	-0.0017 mA	-0.011%
75.00 °C	16.0000 mA	15.9995 mA	-0.0005 mA	-0.003%
50.00 °C	12.0000 mA	11.9924 mA	-0.0076 mA	-0.047%
25.00 °C	8.0000 mA	7.9975 mA	-0.0025 mA	-0.016%
0.00 °C	4.0000 mA	3.9981 mA	-0.0019 mA	-0.012%

Fig. 51 - Task Results

The icon  saves the task data in a PDF file in the internal SD card of the Calibrator.

To save the data in a Pen Drive or External HD, press the icon  after saving data.

To print the Calibration Report, press the icon . The printer must have been previously configured in **SETTINGS > SYSTEM > PRINTER CONFIG** (see section 3.3) and connected to the MCS-XV USB Host port (see **Figures 02, 04 and 05**, portable, RM and DT versions, respectively).

To access the files saved in the internal SD card of the calibrator, connect the USB cable to the computer (type A USB) and to the MCS-XV (Type B USB - Device, see **Figures 02, 04 and 05**, portable, RM and DT versions, respectively).

The Report logo can be changed for one of your own company. For this, connect a USB cable between MCS-XV USB Device port and a computer. Change the file LOGO.bmp for your logo file (must be .bmp extension). We recommend an image close to 200 x 200 pixels.

To add your sign to the Report, create a user with a signature in System Menu (See section 3.3 - System) and enable the Protected Access with password.

Calibration report for tag TT01

TASK DETAILS

CREATED IN: 03/02/2016
 INSTRUMENT DETAILS:
 TAG: TT01
 SERIAL NUMBER: 001.01.15
 MODEL: RTD Transmitter
 MANUFACTURER: Presys
 INPUT RANGE: 0 TO 100 °C (RTD)
 OUTPUT RANGE: 4 TO 20 mA
 MAX ERROR = 0.1% SPAN(SPAN = 16 mA)
 LEAD TIME: 10 SECONDS

As-found performed by: John A.

POINT	EXPECTED	OBTAINED	ERROR	SPAN ERR.	PASS/FAIL
0.00 °C	4.0000 mA	3.9955 mA	-0.0045 mA	-0.028%	Pass
25.00 °C	8.0000 mA	7.9907 mA	-0.0093 mA	-0.058%	Pass
50.00 °C	12.0000 mA	11.9897 mA	-0.0103 mA	-0.064%	Pass
75.00 °C	16.0000 mA	15.9934 mA	-0.0066 mA	-0.041%	Pass
100.00 °C	20.0000 mA	19.9968 mA	-0.0032 mA	-0.020%	Pass

As-left performed by: John A.

POINT	EXPECTED	OBTAINED	ERROR	SPAN ERR.	PASS/FAIL
0.00 °C	4.0000 mA	4.0001 mA	0.0001 mA	0.001%	Pass
25.00 °C	8.0000 mA	7.9949 mA	-0.0051 mA	-0.032%	Pass
50.00 °C	12.0000 mA	11.9911 mA	-0.0089 mA	-0.056%	Pass
75.00 °C	16.0000 mA	15.9932 mA	-0.0068 mA	-0.042%	Pass
100.00 °C	20.0000 mA	19.9957 mA	-0.0043 mA	-0.027%	Pass
0.00 °C	4.0000 mA	3.9983 mA	-0.0017 mA	-0.011%	Pass
25.00 °C	8.0000 mA	7.9995 mA	-0.0005 mA	-0.003%	Pass
50.00 °C	12.0000 mA	11.9924 mA	-0.0076 mA	-0.047%	Pass
75.00 °C	16.0000 mA	15.9975 mA	-0.0025 mA	-0.016%	Pass
100.00 °C	20.0000 mA	19.9981 mA	-0.0019 mA	-0.012%	Pass



Standard serial number: 112.11.15
 Standard last calibration: 13/11/2015
 Operator signature: 

Fig. 52 - Calibration Report

2.8. Videos

MCS-XV calibrator has a video player. These videos can be viewed while a calibration is performed and are designed to assist in the use of the calibrator.

From the main menu, selecting **VIDEOS** a list of video categories appears. Select the category and the desired video. Press the button  to view the video in full screen and the button  to reduced screen.

To add new videos on the calibrator, connect the USB cable to the computer (type A USB) and to the MCS-XV (Type B USB, see **Figures 02, 04 and 05**, portable, RM and DT versions, respectively). Open **VIDEOS** folder. Copy the new video to any sub-folder (category) of the VIDEOS folder. If you prefer to create a new category, simply create a new folder inside VIDEOS with the name of the desired category and copy the video to this folder.

3 - Settings

The **SETTINGS** menu has three divisions (tabs at the bottom): **DATE AND TIME**, **NETWORK** (IP address of the calibrator) and **SYSTEM**.

3.1. Date and Time

In **Date and Time** tab is configured the date, time and time zone for the calibrator.

3.2. Network

In **NETWORK** tab is configured the IP address of the calibrator to Ethernet communication with the computer. The IP address can be dynamically configured (**DHCP**) or may have a fixed address (disable **DHCP** option and edit the desired address).

Connecting the calibrator to the network you can view and print reports of the tasks on the computer.

3.3. System

In the **SYSTEM** tab can be set the volume of the calibrator, the touch screen calibration, identification of the calibrator, language, printer and security options.

- **Touch Screen Options**

To adjust the touch screen, press the TOUCHSCREEN OPTIONS button. Press on the screen the places indicated by + (it is recommended to use the stylus for touch screen). After the calibration, press again on the screen at any point. Confirm the calibration to return to SYSTEM Menu.

- **Language Setting**

Press the desired language for the system and confirm in OK button. The system must be restarted to save the configuration.

- **Calibrator Identification**



In this option is possible to identify your calibrator, choosing a TAG name, Owner name and Location.

- **Sound Options**

Press + or - to configure a value for the system audio volume.

- **Security Options**

The instrument initially has no access password. This setting can be changed in **SECURITY OPTIONS**.

To create a new user, press the key icon  and then users icon . Fill the blanks and press **CREATE**. It is possible to add a signature to be used the issuing of a calibration report through the **TASK** feature.

Pay attention to the functions that each user level has access in the following table:

User Level	Function				
	Calibrator	Tasks	Hart®	Data-Logger	Settings
Operator	✓	✓	✗	✗	✗
Tec	✓	✓	✓	✓	✗
Admin	✓	✓	✓	✓	✓

To lock the system, press the padlock icon  on **Settings** → **System** menu. The next time the MCS-XV Calibrator is turned on, it will request login and password. To unlock the system, login as an Admin Level user and press the padlock icon on system menu again.

- **Printer Config**

To configure the USB Printer Language (PCL3/PCL5e/PCL3G etc.).

- **Adjust Cal.**

Adjustment level protected by password. (See section 4 - Adjustment)

4 - Adjustment

Warning: Enter the following options only after understanding them completely. Otherwise, it may be necessary to return the instrument to the factory for readjustment.

Press **ADJUST CAL** option from the **SETTINGS > System** Menu. You should then enter the **PASSWORD 9875** to access the adjustment menu.

The password functions as a protection to adjustment ranges. After the password is entered the menu displays the options **GENERAL**, **INPUTS** and **OUTPUTS**. In the option **General** you can Recover the Manufacturer Adjustment backup file and change the last calibration date if a new adjustment is done.

For the adjustment, choose between inputs, outputs and pressure adjustment (General Tab).



Fig. 53 - Adjustment Options

Simply note that the thermocouples will only be adjustment after the **mV** and cold junction (**CJC**) adjustment have been performed. Only in case of **OHM** or **RTD**, you have to perform the **mV** adjustment first.

4.1. Input adjustment (IN)

1) mV, V, mA Inputs

Select the corresponding mnemonic and press **START** button. Apply the signals presented in the tables below.

Note that the applied signals just need to be close to values shown in the table.

Once the signal has been applied, store the values of the 1st and 2nd calibration points (PNT1 and PNT2).

mV Input	PNT1	PNT2
G_4	0.000 mV	70.000 mV
G_3	0.000 mV	120.000 mV
G_2	0.000 mV	600.00 mV
G_1	600.00 mV	2400.00 mV

V Input	PNT1	PNT2
Single range	0.0000 V	11.0000 V

mA Input	PNT1	PNT2
Single range	0.0000 mA	20.0000 mA

2) OHMS Input

Input adjustment for Ω is performed in two steps:

a) Application of mV signal:

For the adjustment below, leave terminals RTD3(+) and RTD4(+) short-circuited

mV Signal	Terminals	PNT1	PNT2
V_OHM3	RTD3(+) and GND IN (-)	70.000 mV	120.000 mV
V_OHM4	RTD4(+) and GND IN (-)	70.000 mV	120.000 mV

b) Application of Resistance:

Connect a decade-box or standard resistors on terminals RTD1, RTD2, RTD3 and RTD4 (4-wire connection).

resistors	PNT1	PNT2
OHM3	20.000 Ω	50.000 Ω
OHM2	100.000 Ω	500.000 Ω
OHM1	500.000 Ω	2200.000 Ω

3) CJC Adjustment

Measure the temperature of input terminal GND IN and store only one point.

Cold Junction	PNT1
CJC	32.03 °C

4.2. Output adjustment (OUT)

The output adjustment (except for CJC and Probe) is performed in STEPS. For each STEP the calibrator outputs a signal of the same type selected which must be measured and stored.

1) V, mV and mA Outputs

For these output ranges, the display shows three buttons: **STEP1**, **STEP2** and **STEP3**. Select **STEP1**. The signal generated should be measured by a standard and the value must be stored, by pressing **SAVE** button. Repeat the procedure for **STEP2** and **STEP3**.

2) OHM Output

Due to accuracy reasons, the resistance output must be measure by a standard using 4-wire connection. Initially, the polarity of the wires is not important as the excitation current can flow in one or the other direction - from RTD1 to RTD2 terminal or from RTD2 to RTD1 terminal.

The adjustment should be performed for both ranges: 400 Ω (OHM-400) and 2500 Ω (OHM-2500).

For these output ranges, the display shows four buttons: **STEP1**, **STEP2**, **STEP3** and **STEP4**. Select **STEP1**. The signal generated should be measured by a standard and the value must be stored, by pressing **SAVE** button. Repeat the procedure for **STEP2** and **STEP3**. Change the plugs connected to RTD1 terminal with the ones connected to RTD2 terminal and select **STEP4**. Measure the signal generated and store the standard value.

3) Probe adjustment

First identify the connector pins for **Probe** input according to the figure below.

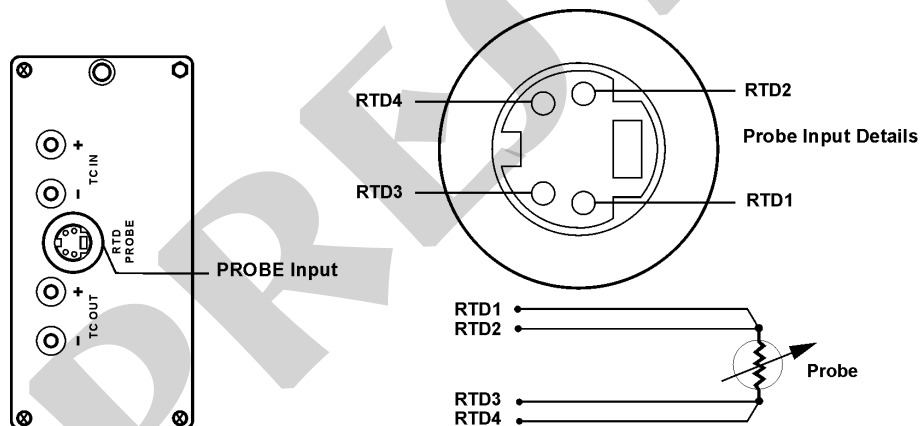

Fig. 54 – PROBE input connector

The **PROBE** adjustment is performed in two steps:

84

a) Application of mV signal:

mV Signal	Terminals	Bornes	PNT1	PNT2
V_2	RTD2(+)*	GND OUT (-)	70.000mV	120.000 mV
V_1	RTD2(+)*	GND OUT (-)	120.000mV	600.00 mV

(*) RTD2, for **PROBE** adjustment, refers to the drawing shown in Figure 54.

b) Application of standard resistors:

Connect a decade box or standard resistor to the probe connector, at positions RTD1, RTD2, RTD3 and RTD4, as shown in Figure 54.

resistors	PNT1	PNT2
R_2	20.000 Ω	50.000 Ω
R_1	100.000 Ω	500.000 Ω

4) CJC adjustment

The adjustment of the cold junction related to the thermocouple output is similar to the one related to the thermocouple input. But the temperature should be taken at the GND OUT terminal.

4.3. Pressure Calibration

By pressing **Pressure Adjust** in the General Tab, there are 3 options: **mV ADJUSTMENT**, **PRESSURE ADJUSTMENT** and **PARAMETERS CONFIGURATION**. Enter the **PRESSURE ADJUSTMENT** option.

The calibration of the sensors consists of the application of at least two pressure values: one close to the minimum range value and the other on the full scale (FS) of the pressure sensor.

The number of adjustment points can be increased depending on the pressure sensor.

PRESSURE ADJUSTMENT:

PRESSURE SENSOR
C1

NON ADJUSTED PRESSURE 0.0003 psi
ADJUSTED PRESSURE 0.0007 psi

POINT
POINT 3

SAVED POINT 0.0000 psi
POINT SAVED 0.0000 psi

Fig. 55 – Pressure Adjustment

Select a pressure sensor between **C1**, **C2**, **C3** and **C4**. Press **START**.

Choose an adjustment point and verify the pressure value to be applied. Apply the pressure and press **SAVE** button.

5 - Maintenance

5.1. Replacing Battery (only for MCS-XV Portable)

To change the MCS-XV battery, proceed as follows:

- Loosen the screws on the battery cover as shown in figure 56 (A);
- Disconnect the battery and pull it, see figures 56 (B) and (C);
- Insert the new battery and connect it, as shown in figure 56 (D);
- Close the lid, see figure 56 (E).



(A)



(B)

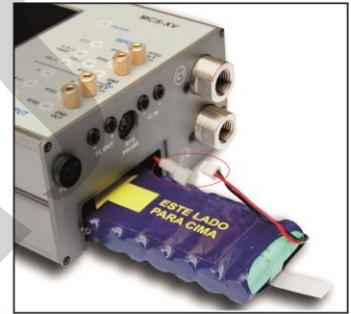

(C)



(D)



(E)

Fig. 56 - Replacing Battery

5.2. Replacing Current Input Fuse

To replace the current fuse of MCS-XV, proceed as follows:

- Rotate the fuse holder counterclockwise, as shown in figure 57 (A). Try to use a plastic tool to avoid damaging the fuse holder;
- The fuse holder will be released, as shown in 57 (B);
- Pull the fuse holder and remove the fuse, see figure 57 (C);
- Place the spare fuse. The fuse is in the carrying case;



(A)



(B)



(C)

Fig. 57 - Replacing current input fuse

6 - Pressure Units Conversion

psi	bar	mbar	mPa	kPa
1	0.06894757	68.94757	0.006894757	6.894757

psi	Pa	atm	at	mmH ₂ O@4°C
1	6894.757	0.06804596	0.07030695	703.0890

psi	cmH ₂ O@4°C	ftH ₂ O@4°C	inH ₂ O@4°C	inH ₂ O@60°F
1	70.30889	2.306726	27.68067	27.70759

psi	torr	mmHg@0°C	cmHg@0°C	inHg@0°C
1	51.71507	51.71507	5.171507	2.036026

psi	inHg@60°F	gf/cm ²	kgf/cm ²	kgf/m ²
1	2.041772	70.30695	0.07030695	703.0695

Notes

- Adjusting procedures for MCS-XV must be performed under the reference conditions of temperature and humidity.
- Better calibration results are achieved if warm-up time is at least two hours and if the battery charger remains disconnected from the calibrator since one hour before its usage.
- The standards used to adjust MCS-XV should have accuracy at least 3 times better than the accuracy values provided in this manual.

PRESYS

PRESYS

| Instruments Inc.

www.presyscorp.com