

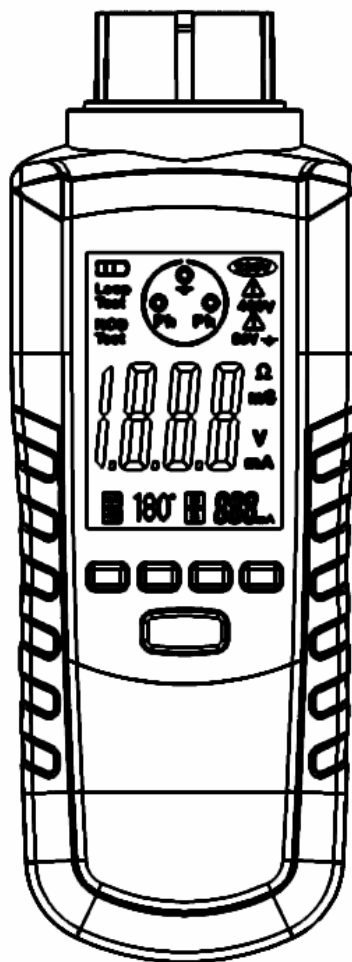

WCM-RCD Digital RCD Tester



Wavecom Instruments Pty Ltd

Ph: (+61) 08 8243 3500 Fax: (+61) 08 8243 3501

257 Grange Road, Findon SA 5023

Email: sales@wavecom.com.au

Web: www.wavecom.com.au





Warnings

Before using this appliance, please read the documentation and make sure you fully understand the information it contains.

Do not use the appliance on mains voltages greater than 240VAC. Please inspect the appliance before use. Do not use the appliance if it is damaged in any way.

If a 400V icon is displayed, disconnect the appliance immediately and get a qualified electrician check the electrical installation.

This device is designed to trip residual current devices. Once the RCD is tripped there will be no power on the supply circuit. Before using the appliance, you must check that tripping the RCD to the power system will not disrupt any people from working or damage equipment (medical, computers, industrial plant, etc.).

This device contains no user serviceable parts and should be returned to the place of purchase for repair.

Do not attempt to continue the tests if the default voltage (50V) is displayed (calculated for $I-\Delta n$); then check the installation.

Leakage currents from other appliances can give incorrect measurements on the RCD tester if they are connected in the same circuit.

This appliance is fitted with four 1.5V 'AA' batteries;
Please comply with the correct waste disposal procedures in your area.

To maintain stated accuracies during repeated use, allow 60 seconds between testing to adequately dissipate any heat buildup when performing tests of greater than 100mA.

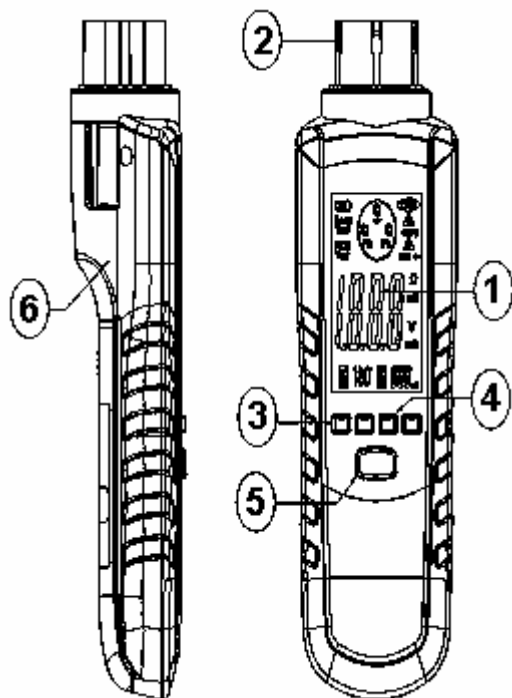

1. LCD display (blue/red)
2. Plugs for 2P+T Sockets
3. “ On” and selection button
4. Selection buttons
5. Test button and Off
6. Non-slip coating

The RCD tester

The main function of the tester is to test and measure the trip values of RCD (Residual Current Devices):

- in trip time (expressed in ms) or
- in trip current value (expressed in mA).

This enables 10mA / 30mA / 100mA/ 300mA / 500mA and 650mA Residual Current breakers to be tested irrespective of their type (normal or delayed).

This tester can also be used to test the configuration of the network and the connection of the earthing conductor.

The back light, dual colour screen immediately informs you whether the values measured are compliant (blue) or not compliant (red).

Switching the appliance on and off

Switching on the tester:

-a: press and hold the On (mA/mS) button for more than 2 sec., the screen then displays the selection table

-b: connect the appliance to a socket, the screen displays the selection table but also the socket configuration. The

RCD tester will switch off automatically if it is not used after 50 seconds.

Testing the socket and mains supply

- The phase position (the left or right) shows how the VAC is configured from the GPO
- The earth symbol displays the presence of the earth connection.
- If the 400V Symbol appears while connected to a 240VAC GPO then the input voltage is out of range, when this is displayed no more measurements can be taken.

Warning of contact potential

The RCD tester is designed to leak current to the ground circuit, this may cause a dangerous increase in potential on the earth circuit (particularly if the earth conductance is poor). During the RCD test the voltage is measured at the testers ground connection. The ground potential must not exceed 50V (safety voltage).

If the ground potential happens to be greater, any continuation of the test is prohibited. The appliance switches to the red back lighting and warning signal appears.

Measuring and testing

Selection of the Time Test and Ramp type: Before testing an RCD, you must select the characteristics on the display (0 deg / 180 deg, delayed or not) together with the type of test that you are required to perform (trip time or current).

The functions are listed under each button. The characteristics of the test are selected by the outlined rectangle on the LCD screen.

Note: The selection can be made with the tester disconnected. Switch on the tester and select the test characteristics. If the tester is connected to a live GPO the tester will switch on automatically.

1 –Selecting the type of test (current or time):

The first navigation button is used to choose between testing your RCDs:

-Current: The tester shows the “mA” measurement unit on the screen.

-Time: The tester shows the “ms” measurement unit on the screen.

2 –Selecting 0° or 180°

RCDs can react differently depending whether the default current starts with a positive half-cycle (0°) or a negative half-cycle (180°). The tester automatically sets itself to a current starting with a positive half-cycle (0°). If you want to perform a test that starts with a negative half-cycle press the 0/180° button. The LCD selection will change to 180°.

3 –Normal/Delayed selection:

Use the third button to choose the RCD type: N (normal: not delayed, instant trip) or S* (delayed)*. During delayed tests the tester will display a delay timer which counts down from 30s to 0s before performing the RCD test. S-type RCD's are not required as part of the Australian Standards, AS3760.

4 –Selecting the RCD sensitivity:

Use the right-hand button to select the appropriate sensitivity (assigned current for differential trip): 10mA / 30mA / 100mA / 300mA / 500mA or 650mA

Note: each time the tester is switched on, the tester will revert back to the most common test settings (30 mA/N/ 0° /ms).

Measurement results

Once the selections have been made, press the red TEST button. The digital result is shown and the back lighting:

- stays blue if the result is correct
- goes to red if the values not compliant

Battery Replacement

1, When the low battery symbol” ” appears on the LCD,

The four 1.5V ‘AA’ batteries must be replaced.

2, Remove the screw holding the battery cover 3, Remove the battery compartment cover

4, Replace the batteries observing polarity 5, Affix the rear cover and secure the screw.

Technical Specifications

1. 3-digit measurement display
2. N or S (delayed) type RCD test, - AC or A (continuous component detection)
3. Operates on a TT neutral and TN system
4. Operating voltage: 230V (Ph./N) – 10/+6% 50/60 Hz
5. Cat III 600V
6. Double insulation

- 1 IEC 61010-1
- 2 IEC 61557-6 NF EN 61557-6
- 3 IEC 61236 (EMC)
- 4 Locking and warning signals for 400V network
voltage and contact potential >50V
- 5 Operating temperature: -15°C /+45°C
- 6 Storage temperature: -25°C /+70°C
- 7 IP40
- 8 Resistance to mechanical shock:1G
- 9 Weight : 340g
- Dimensions: w=71mm l=210mm h=51mm
- Four 1.5V 'AA' batteries

